

Harmony

HMI GTO for EcoStruxure™ Operator Terminal Expert Hardware Guide

11/2019

The information provided in this documentation contains general descriptions and/or technical characteristics of the performance of the products contained herein. This documentation is not intended as a substitute for and is not to be used for determining suitability or reliability of these products for specific user applications. It is the duty of any such user or integrator to perform the appropriate and complete risk analysis, evaluation and testing of the products with respect to the relevant specific application or use thereof. Neither Schneider Electric nor any of its affiliates or subsidiaries shall be responsible or liable for misuse of the information contained herein. If you have any suggestions for improvements or amendments or have found errors in this publication, please notify us.

You agree not to reproduce, other than for your own personal, noncommercial use, all or part of this document on any medium whatsoever without permission of Schneider Electric, given in writing. You also agree not to establish any hypertext links to this document or its content. Schneider Electric does not grant any right or license for the personal and noncommercial use of the document or its content, except for a non-exclusive license to consult it on an "as is" basis, at your own risk. All other rights are reserved.

All pertinent state, regional, and local safety regulations must be observed when installing and using this product. For reasons of safety and to help ensure compliance with documented system data, only the manufacturer should perform repairs to components.

When devices are used for applications with technical safety requirements, the relevant instructions must be followed.

Failure to use Schneider Electric software or approved software with our hardware products may result in injury, harm, or improper operating results.

Failure to observe this information can result in injury or equipment damage.

© 2019 Schneider Electric. All rights reserved.

Table of Contents



	Safety Information	5
	About the Book	7
Chapter 1	Overview	9
	Part Numbers	10
	HMIGTO Package Contents	11
	Certifications and Standards	12
	GTO Series of Panels	14
Chapter 2	Device Connectivity	17
	System Design	18
	Accessories	19
Chapter 3	Parts Identification and Functions	23
	Parts Identification and Functions	23
Chapter 4	Specifications	33
4.1	HMIGTO1300/1310	34
	Electrical Specifications	35
	Environmental Specifications	36
	Structural Specifications	37
	Display Specifications	38
	Memory, Clock, Touch Panel, and Function Switches	39
	Interface Specifications	40
	Specifications of Serial Interface COM1	41
	Specifications of Serial Interface COM2	43
	Dimensions	44
4.2	HMIGTO2300/2310/2315	47
	Electrical Specifications	48
	Environmental Specifications	49
	Structural Specifications	50
	Display Specifications	52
	Memory, Clock, and Touch Panel	53
	Interface Specifications	54
	Specifications of Serial Interface COM1	55
	Specifications of Serial Interface COM2	57
	Dimensions	58
4.3	HMIGTO3510/4310	62
	Electrical Specifications	63
	Environmental Specifications	64
	Structural Specifications	65
	Display Specifications	66
	Memory, Clock, and Touch Panel	67
	Interface Specifications	68
	Specifications of Serial Interface COM1	69
	Specifications of Serial Interface COM2	71
	Dimensions	72
4.4	HMIGTO5310/5315	76
	Electrical Specifications	77
	Environmental Specifications	78
	Structural Specifications	79
	Display Specifications	81
	Memory, Clock, and Touch Panel	82

	Interface Specifications	83
	Specifications of Serial Interface COM1	84
	Specifications of Serial Interface COM2	86
	Dimensions	87
4.5	HMIGTO6310/6315	91
	Electrical Specifications	92
	Environmental Specifications	93
	Structural Specifications	94
	Display Specifications	96
	Memory, Clock, and Touch Panel	97
	Interface Specifications	98
	Specifications of Serial Interface COM1	99
	Specifications of Serial Interface COM2	101
	Dimensions	102
Chapter 5	Installation and Wiring	107
5.1	Installation	108
	Installation Procedures	108
5.2	Wiring Principles	113
	Connecting the Power Cord	114
	Connecting the Power Supply	116
	Grounding	118
5.3	SD Card Insertion/Removal	119
	Introduction	120
	Inserting the SD Card	121
	Removing the SD Card	122
	SD Card Data Backup	123
5.4	USB Cable Clamp	124
	USB Cable Clamp for USB (Type A)	125
	USB Holder for USB (mini-B)	127
Chapter 6	Maintenance	129
	Regular Cleaning	130
	Replacing the Installation Gasket	131
	Periodic Check Points	133
	Replacing the Primary Battery	134
Index	137



Important Information

NOTICE

Read these instructions carefully, and look at the equipment to become familiar with the device before trying to install, operate, service, or maintain it. The following special messages may appear throughout this documentation or on the equipment to warn of potential hazards or to call attention to information that clarifies or simplifies a procedure.



The addition of this symbol to a “Danger” or “Warning” safety label indicates that an electrical hazard exists which will result in personal injury if the instructions are not followed.



This is the safety alert symbol. It is used to alert you to potential personal injury hazards. Obey all safety messages that follow this symbol to avoid possible injury or death.

DANGER

DANGER indicates a hazardous situation which, if not avoided, **will result in** death or serious injury.

WARNING

WARNING indicates a hazardous situation which, if not avoided, **could result in** death or serious injury.

CAUTION

CAUTION indicates a hazardous situation which, if not avoided, **could result in** minor or moderate injury.

NOTICE

NOTICE is used to address practices not related to physical injury.

PLEASE NOTE

Electrical equipment should be installed, operated, serviced, and maintained only by qualified personnel. No responsibility is assumed by Schneider Electric for any consequences arising out of the use of this material.

A qualified person is one who has skills and knowledge related to the construction and operation of electrical equipment and its installation, and has received safety training to recognize and avoid the hazards involved.

About the Book



At a Glance

Document Scope

This manual describes how to use the HMIGTO panels.

Validity Note

This documentation is valid for EcoStruxure™ Operator Terminal Expert.

The technical characteristics of the devices described in the present document also appear online. To access the information online:

Step	Action
1	Go to the Schneider Electric home page www.schneider-electric.com .
2	In the Search box type the reference of a product or the name of a product range. <ul style="list-style-type: none">• Do not include blank spaces in the reference or product range.• To get information on grouping similar modules, use asterisks (*).
3	If you entered a reference, go to the Product Datasheets search results and click on the reference that interests you. If you entered the name of a product range, go to the Product Ranges search results and click on the product range that interests you.
4	If more than one reference appears in the Products search results, click on the reference that interests you.
5	Depending on the size of your screen, you may need to scroll down to see the datasheet.
6	To save or print a datasheet as a .pdf file, click Download XXX product datasheet .

The characteristics that are presented in the present document should be the same as those characteristics that appear online. In line with our policy of constant improvement, we may revise content over time to improve clarity and accuracy. If you see a difference between the document and online information, use the online information as your reference.

Product Related Information

WARNING

UNINTENDED EQUIPMENT OPERATION

The application of this product requires expertise in the design and programming of control systems. Only persons with such expertise should be allowed to program, install, alter, and apply this product.

Follow all local and national safety standards.

Failure to follow these instructions can result in death, serious injury, or equipment damage.

Chapter 1

Overview

Overview

This chapter describes the HMIGTO panels and general topics such as package contents and standards.

What Is in This Chapter?

This chapter contains the following topics:

Topic	Page
Part Numbers	10
HMIGTO Package Contents	11
Certifications and Standards	12
GTO Series of Panels	14

Part Numbers

Software EcoStruxure Operator Terminal Expert

The part numbers of the models supported by EcoStruxure Operator Terminal Expert:

Series	Display size	Part numbers	Revisions
Harmony GTO	3.5-inch	HMIGTO1300	PV: 03 or later
		HMIGTO1310	
	5.7-inch	HMIGTO2300	PV: 03 or later
		HMIGTO2310	
		HMIGTO2315	
	7.0-inch	HMIGTO3510	PV: 03 or later
	7.5-inch	HMIGTO4310	PV: 03 or later
	10.4-inch	HMIGTO5310	PV: 04 or later
		HMIGTO5315	
	12.1-inch	HMIGTO6310	PV: 04 or later
HMIGTO6315			

Revision

You can identify the product version (PV), revision level (RL), and the software version (SV) from the unit product label:

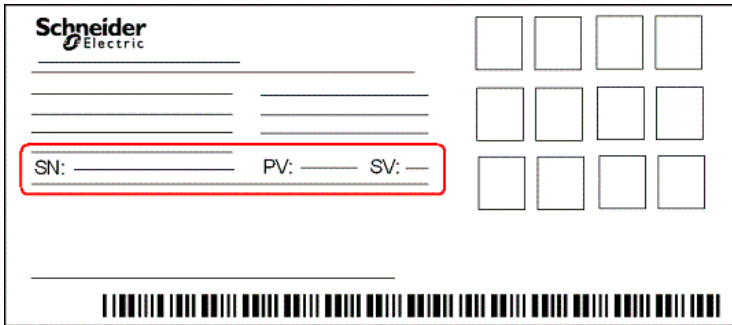

HMIGTO Package Contents

Overview

Verify all items listed here are present in your package:

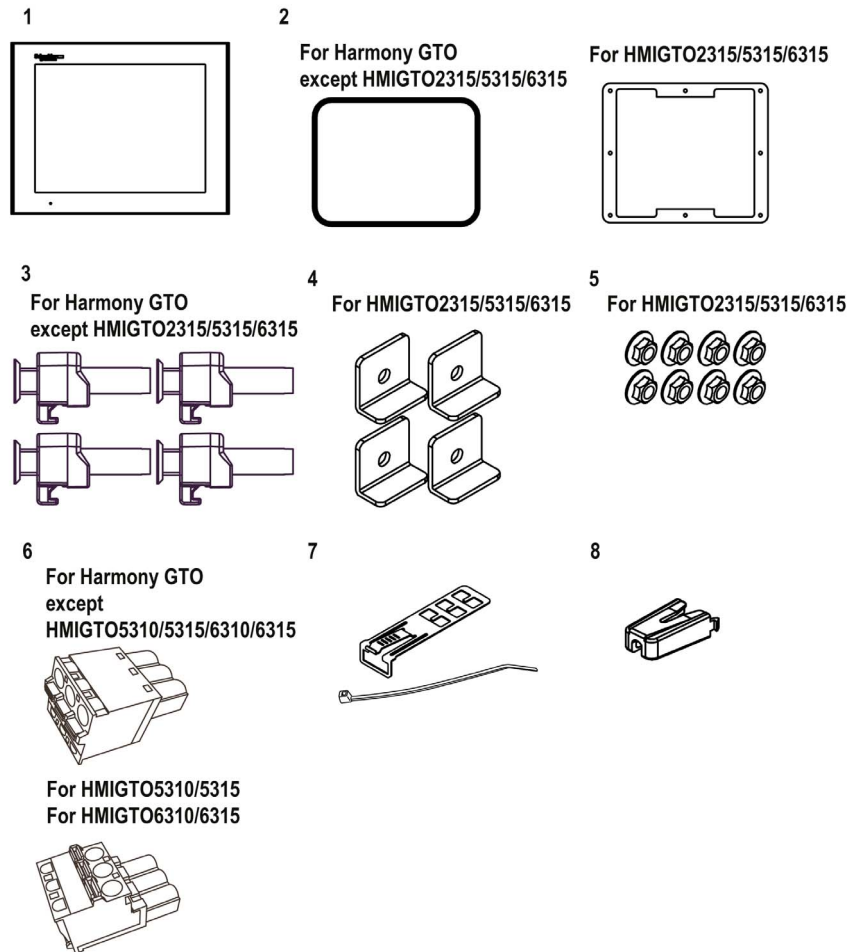

- 1 HMIGTO: 1
- 2 Installation gasket: 1 (attached to the panel)
- 3 Installation fasteners: 4 per set
- 4 Brackets: 4
- 5 M4 Hex Nuts: 8
- 6 DC power connector: 1*1
- 7 USB cable clamp Type A: 1 set (1 clip and 1 tie)
- 8 USB cable clamp mini-B: 1 (1 USB holder)
- 9 HMIGTO Quick Reference Guide: 1

This product has been carefully packed with special attention to quality. However, should you find anything damaged or missing, contact your local distributor.

*1 You can use the DC power connector for HMIGTO1300/1310 / HMIGTO2300/2310/2315 / HMIGTO3510/4310 to supply power to HMIGTO5310/5315 / HMIGTO6310/6315. However the reverse is not possible. You cannot use the power connector for HMIGTO5310/5315 / HMIGTO6310/6315 on HMIGTO1300/1310 / HMIGTO2300/2310/2315 / HMIGTO3510/4310.

Certifications and Standards

Introduction

Schneider Electric submitted this product for independent testing and qualification by third-party listing agencies. These agencies have certified this product as meeting the following standards.

Agency Certifications

The HMIGTO is manufactured in accordance with:

- Standard UL 508 and CSA C22.2 n°142 for Industrial Control Equipment
- Standard ANSI/ISA - 12.12.01 and CSA C22.2 n°213 for Electrical Equipment for Use in Class I, Division 2 Hazardous Locations

NOTE:

- For use in Pollution Degree 2 environments.
- For use on a flat surface of a Type 1, Type 4X (Indoor Use Only) or Type 13 Enclosure.
- 24 Vdc input panel must be used with a Class 2 power supply.
- Suitable for use in Class I, Division 2 Groups A, B, C, and D Hazardous Locations.

- GOST certification.
Refer to product markings.
- ATEX certification by Technical Inspection Association.
Refer to product label.
- Merchant Navy rules. (Except Harmony GTOxxx5.)
Products are designed to comply with Merchant Navy rules.
Refer to the Schneider Electric Web site for Merchant Navy rules installation guidelines.
- Standard EN1672-2 (Harmony GTOxxx5).
- FDA regulation 21 CFR 177 (Harmony GTOxxx5).

Refer to the Schneider Electric web site for installation guidelines.

For detailed information, contact your local distributor or see the catalog & marking on the product.

Hazardous Substances

The HMIGTO is a device for use in factory systems. When using the HMIGTO in a system, the system should comply with the following standards with regard to the installation environment and handling:

- WEEE, Directive 2002/96/EC
- RoHS, Directive 2011/65/EU
- RoHS China, Standard SJ/T 11363-2006

CE Markings

This product conforms to the requirements of the following Directives for applying the CE label:

- 2006/95/EC Low Voltage Directive
- 2004/108/EC EMC Directive

This conformity is based on compliance with EN61000-6-4, EN61000-6-2

 DANGER
POTENTIAL FOR EXPLOSION
<ul style="list-style-type: none">• Verify that the power, input, and output (I/O) wiring are in accordance with Class I, Division 2 wiring methods.• Substitution of any component may impair suitability for Class I, Division 2.• Do not connect or disconnect equipment unless power has been switched off or the area is known to be non-hazardous.• Securely lock externally connected units and each interface before turning on the power supply.• Do not use, connect, or disconnect USB cable unless area is known to be non-hazardous.• Do not disconnect while circuit is live or unless the area is known to be free of ignitable concentrations.• Potential electrostatic charging hazard. Wipe the front panel of the terminal with a damp cloth before turning ON.
Failure to follow these instructions will result in death or serious injury.

KC Markings

해당 무선설비는 운용 중 전파혼신 가능성이 있음

사용자안내문

기종별	사용자안내문
A급 기기 (업무용 방송통신기자재)	이 기기는 업무용(A급) 전자파적합기기로서 판매자 또는 사용자는 이 점을 주의하시기 바라며, 가정외의 지역에서 사용하는 것을 목적으로 합니다.

해당 무선설비는 전파혼신 가능성이 있으므로 인명안전과 관련된 서비스는 할 수 없습니다

GTO Series of Panels

Critical Systems, Alarms, and Handling Requirements

Critical alarm indicators and system functions require independent and redundant protection hardware and/or mechanical interlocks.

When you cycle power, wait at least 10 seconds before restoring the power to the panel after it has been turned off. Switching the power OFF and ON can damage the panel.

In the event the screen cannot be properly read, for example, if the backlight is not functioning, it may be difficult or impossible to identify a function. Functions that may present a hazard if not immediately executed, such as a fuel shut-off, must be provided independently of the panel. The machine's control system design must take into account the possibility of the backlight no longer functioning and the operator being unable to control the machine or making mistakes in the control of the machine.

WARNING

LOSS OF CONTROL

- The designer of any control scheme must consider the potential failure modes of control paths and, for certain critical control functions, provide a means to achieve a safe state during and after a path failure. Examples of critical control functions are emergency stop and overtravel stop, power outage, and restart.
- Separate or redundant control paths must be provided for critical control functions.
- System control paths may include communication links. Consideration must be given to the implications of unanticipated transmission delays or failures of the link.
- Observe all accident prevention regulations and local safety guidelines.
- Each implementation of this equipment must be individually and thoroughly tested for proper operation before being placed into service.
- The machine control system design must take into account the possibility of the backlight no longer functioning and the operator being unable to control the machine, or making errors in the control of the machine.

Failure to follow these instructions can result in death, serious injury, or equipment damage.

For additional information, refer to NEMA ICS 1.1 (latest edition), "Safety Guidelines for the Application, Installation, and Maintenance of Solid State Control" and to NEMA ICS 7.1 (latest edition), "Safety Standards for Construction and Guide for Selection, Installation and Operation of Adjustable-Speed Drive Systems" or their equivalent governing your particular location.

WARNING

UNINTENDED EQUIPMENT OPERATION

- Do not use this equipment as the only means of control for critical system functions such as motor start/stop or power control.
- Do not use this equipment as the only notification device for critical alarms, such as device overheating or overcurrent.

Failure to follow these instructions can result in death, serious injury, or equipment damage.

Handling the LCD Panel

The following characteristics are specific to the LCD panel and are considered normal behavior:

- LCD screen may show unevenness in the brightness of certain images or may appear different when seen from outside the specified viewing angle. Extended shadows, or crosstalk may also appear on the sides of screen images.
- LCD screen pixels may contain black and white colored spots and color display may seem to have changed.
- When the same image is displayed on the screen for a long period, an after-image may appear when the image is changed.

NOTE: Change the screen image periodically and try not to display the same image for a long period of time.

CAUTION

SERIOUS EYE AND SKIN INJURY

The liquid in the LCD panel contains an irritant:

- Avoid direct skin contact with the liquid.
- Wear gloves when you handle a broken or leaking unit.
- Do not use sharp objects or tools in the vicinity of the LCD touch panel.
- Handle the LCD panel carefully to prevent puncture, bursting, or cracking of the panel material.

Failure to follow these instructions can result in injury or equipment damage.

If the panel is damaged and any liquid comes in contact with your skin, immediately rinse the area with running water for at least 15 minutes. If the liquid gets in your eyes, immediately rinse your eyes with running water for at least 15 minutes and consult a doctor.

Chapter 2

Device Connectivity

Introduction

This chapter presents the equipment you can connect to the panel.

What Is in This Chapter?

This chapter contains the following topics:

Topic	Page
System Design	18
Accessories	19

System Design

Introduction

The following diagrams represent equipment you can connect to the panel.

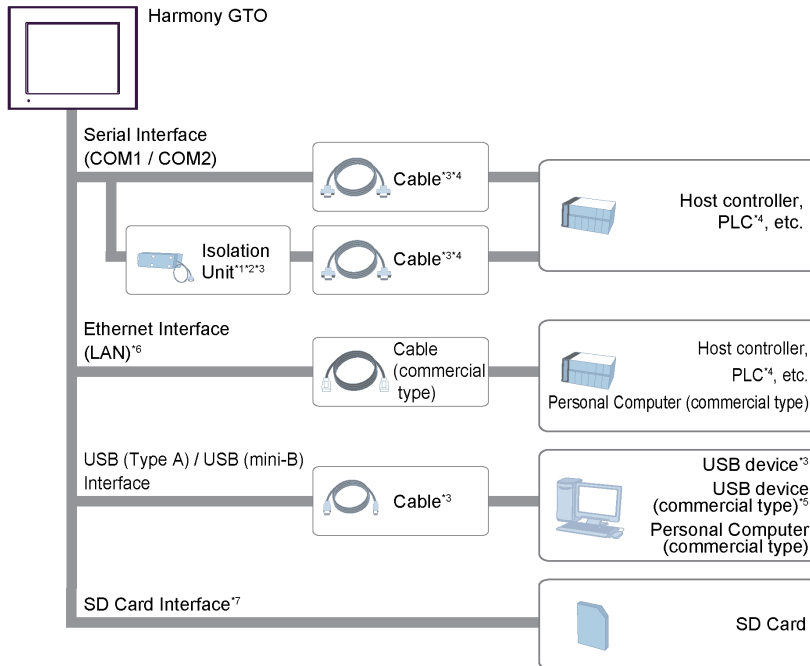

*1 When connecting the XBTZGI232, the COM port's pin 9 setting should be VCC.

*2 Use the Isolation Unit's USB port to supply power to itself. There is no need to set up a separate power supply.

*3 Refer to Accessories ([see page 19](#)).

*4 For information on how to connect controllers and other types of equipment, refer to the corresponding device driver manual of your screen editing software.

*5 For supported models, contact your local Schneider Electric support representative.

*6 The HMIGTO1300 and HMIGTO2300 do not have an Ethernet interface.

*7 The HMIGTO1300/1310 and HMIGTO2300 do not have a SD card interface.

Accessories

Serial Interface Items

For host controllers and connection cables, refer to the corresponding device driver manual of your screen editing software.

Product Name	Product Number	Description
RS-232C Isolation Unit	XBTZGI232	Connects a host controller to HMIGTO with isolation. (RS-232C and RS-422 are switchable.)
RS-485 Isolation Unit	XBTZGI485	Connects a host controller to HMIGTO with isolation.
Terminal Block Conversion Adapter	XBTZG949	To be used when using RS-232C isolation unit in RS-422 mode or RS-485 isolation unit. (When the isolation unit connects output from a serial interface of the panel (D-sub 9-pin plug) with an RS-422 terminal block).
COM Port Conversion Adapter	XBTZGCOM1	Conversion adapter required when connecting RS-232C isolation unit with terminal block conversion adapter. (When the isolation unit connects optional RS-422 communication items to COM1 port of the panel).
Online Adapter	XBTZGCOM2	Conversion adapter required when connecting RS-485 isolation unit with terminal block conversion adapter. (When the isolation unit connects optional RS-485 communication items to COM2 port of the panel).
RJ45 to D-Sub 25-pin Conversion Cable	XBTZG939	Connects a RJ45 cable to HMIGTO (D-sub 9-pin plug).
9-pin to 25-pin RS-232C Conversion Cable	XBTZG919	Connects a standard RS-232C cable (D-Sub 25-pin socket) to HMIGTO (D-sub 9-pin plug).

USB Interface Items

Product Name	Product Number	Description
USB Front Cable	XBTZGUSB	Extension cable attaching USB interface to front panel.
USB Transfer Cable (USB Type A/mini-B)	BMXXCAUSBH018 BMXXCAUSBH045	Cable for transferring screen data from a PC (USB Type A) to the panel (USB mini-B).
Remote USB port location for mini-USB	HMIZSUSBB XBTZGUSBB	Extension cable that attaches to the USB (mini-B) interface on the front side of the operation panel.

Software

Product name	Description
EcoStruxure Operator Terminal Expert	Software you install on your computer to create project data for your HMIGTO.

SD Card Items

Product Name	Product Number	Description
SD Memory Card (4 GB)	HMIZSD4G	SD memory card (4 GB, CLASS4)

Option Items

Product Name	Product Number	Corresponding panel	Description
Screen Protection Sheet	XBTZG66	HMIGTO6310/6315	Disposable, dirt-resistant sheet for the HMIGTO screen (5 sheets/set)
	XBTZG65	HMIGTO5310/5315	
	XBTZG64	HMIGTO4310	
	XBTZG63	HMIGTO3510	
	XBTZG62	HMIGTO2300/2310/2315	
	XBTZG60	HMIGTO1300/1310	
UV Protection Sheet	HMIZUV6	HMIGTO6310/6315	Sheet to protect the display from dirt and ultraviolet light
	HMIZUV5	HMIGTO5310/5315	
	HMIZUV4	HMIGTO4310	
	HMIZUV3W	HMIGTO3510	
	HMIZUV2	HMIGTO2300/2310/2315	
	HMIZUV1	HMIGTO1300/1310	
Environment Cover	XBTZECOV6	HMIGTO6310	Disposable, environment cover for the HMIGTO screen (1 sheet/set)
	XBTZECOV5	HMIGTO5310	
	XBTZECOV4	HMIGTO3510/4310	
	XBTZECOV2	HMIGTO2300/2310	
	XBTZECOV1	HMIGTO1300/1310	

Maintenance Options

Product Name	Product Number	Corresponding panel	Description
Installation Fastener	HMIZGFIX	HMIGTO (except HMIGTO2315/5315/6315)	Used to install the HMIGTO into a solid panel (4 pieces/set)
Installation System	HMIZGFIX2	HMIGTO2315/5315/6315	Used to install the HMIGTO into a solid panel. Brackets (4 pieces/set) M4 Hex nuts (8 pieces/set)
Installation Gasket	HMIZG56	HMIGTO6310	Provides dust and moisture resistance when HMIGTO is installed into a solid panel (1 piece)
	HMIZG562	HMIGTO6315	
	HMIZG55	HMIGTO5310	
	HMIZG552	HMIGTO5315	
	HMIZG54	HMIGTO3510/4310	
	HMIZG52	HMIGTO2300/2310	
	HMIZG522	HMIGTO2315	
HMIZG51	HMIGTO1300/1310		
USB Clamp TypeA (1 port)	HMIZGCLP1	Harmony GTO	Clamp to prevent disconnection of USB cable (USB/A, 1 port, 5 clamps/set)
USB Clamp mini-B (1 port)	HMIZSCLP3	Harmony GTO	Clamp to prevent disconnection of USB cable (USB/mini-B, 1 port, 5 clamps/set)
DC Power Supply Connector	HMIZGPWS	HMIGTO3510/4310 HMIGTO2300/2310/2315 HMIGTO1300/1310	Connector to connect DC power supply cables (5 pcs/set)
DC Power Supply Connector (Right-angle)	HMIZGPWS2	HMIGTO6310/6315 HMIGTO5310/5315	Right-angle connector to connect DC power supply cables (5 pcs/set)
Battery for Memory Backup	HMIZGBAT	HMIGTO (except HMIGTO1300/1310 and HMIGTO2300)	Primary battery for memory and time data backup

Product Name	Product Number	Corresponding panel	Description
Panel Cutout Adapter	XBTZGCO4	HMIGTO5310	Panel cutout adapter for mounting HMIGTO5310 in cutout for XBTGT5230.
Insert Label	HMIZLYGO3	HMIGTO3510	Label insert for HMIGTO 7-inch Wide models.
	HMIZLYGO1	HMIGTO1300/1310	Label insert for HMIGTO 3.5-inch models

Chapter 3

Parts Identification and Functions

Parts Identification and Functions

HMIGTO1300/1310 Parts Identification

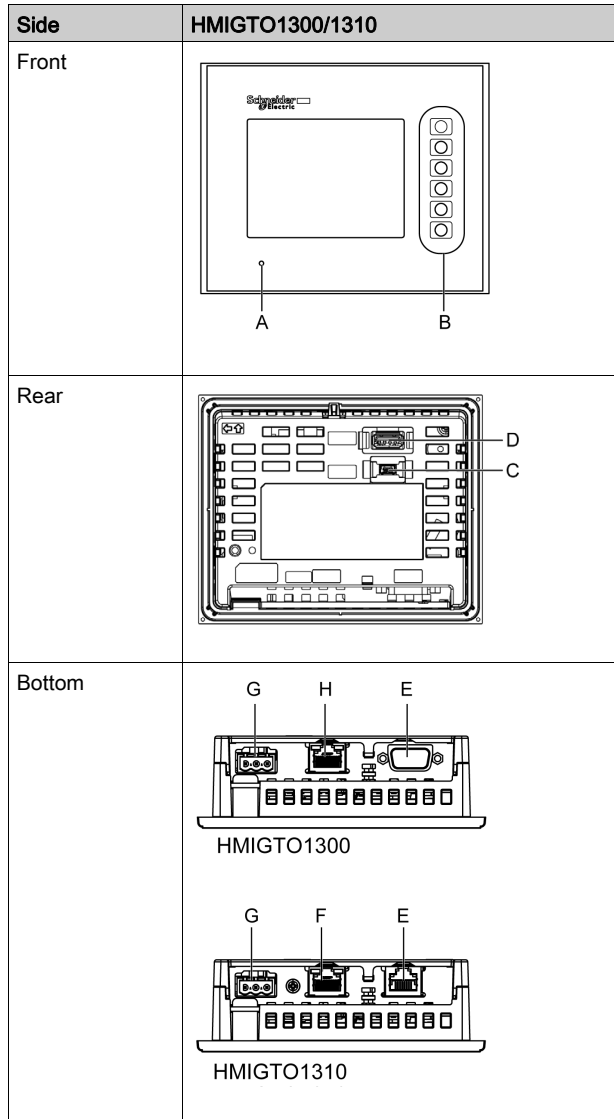

Part	Name	Description
A	Status LED	*1
B	Function Switches	Six switches (F1 to F6). You can define operations for these switches using EcoStruxure Operator Terminal Expert.
C	USB (mini-B) Interface	Conforms to USB2.0 (mini-B) x 1. Communication Distance: 5 m (16.4 ft) or less.
D	USB (Type A) Interface	Conforms to USB2.0 (Type A) x 1. Power supply voltage: 5 Vdc+/-5%. Output Current: 500 mA or less. Maximum communication distance: 5 m (16.4 ft).

Part	Name	Description
E	Serial Interface (COM1)	HMIGTO1300: RS-232C Serial Interface. Connector: D-Sub 9 pin (plug) x 1. HMIGTO1310: RS-232C/485 Serial Interface. (You can switch the communication method via software.) Connector: Modular jack (RJ45).
F	Ethernet Interface ^{*2}	Ethernet transmission interface (10BASE-T/100BASE-TX) Connector: Modular jack (RJ45) x 1. Ethernet Interface is not attached to HMIGTO1300.
G	Power Plug Connector	-
H	Serial Interface (COM2)	HMIGTO1300: RS-485 Serial Interface. Connector: Modular jack (RJ45) x 1.

*1 Status LED operations are as shown below:

Color	Indicator	Description
Green	ON	In operation
Orange	Flashing	Software starting up.
Red	ON	Power is turned ON.
-	OFF	Power is turned OFF.

*2 Ethernet LED operations are as shown below.

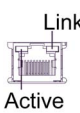
	Color	Indicator	Description
	Green (Active)	Flashing	Data transmission is occurring.
		OFF	No data transmission.
	Green (Link)	ON	Data transmission is available in 10BASE-T/100BASE-TX.
		OFF	No connection or subsequent transmission failure.

HMIGTO2300/2310/2315 Parts Identification

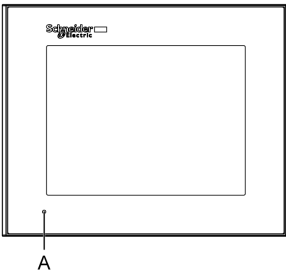
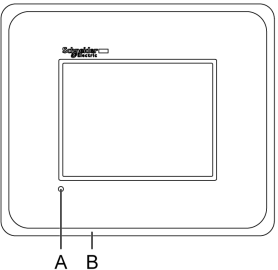
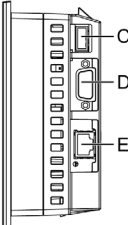
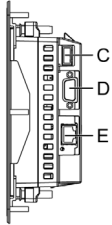
Side	HMIGTO2300 / HMIGTO2310	HMIGTO2315
Front		
Right		

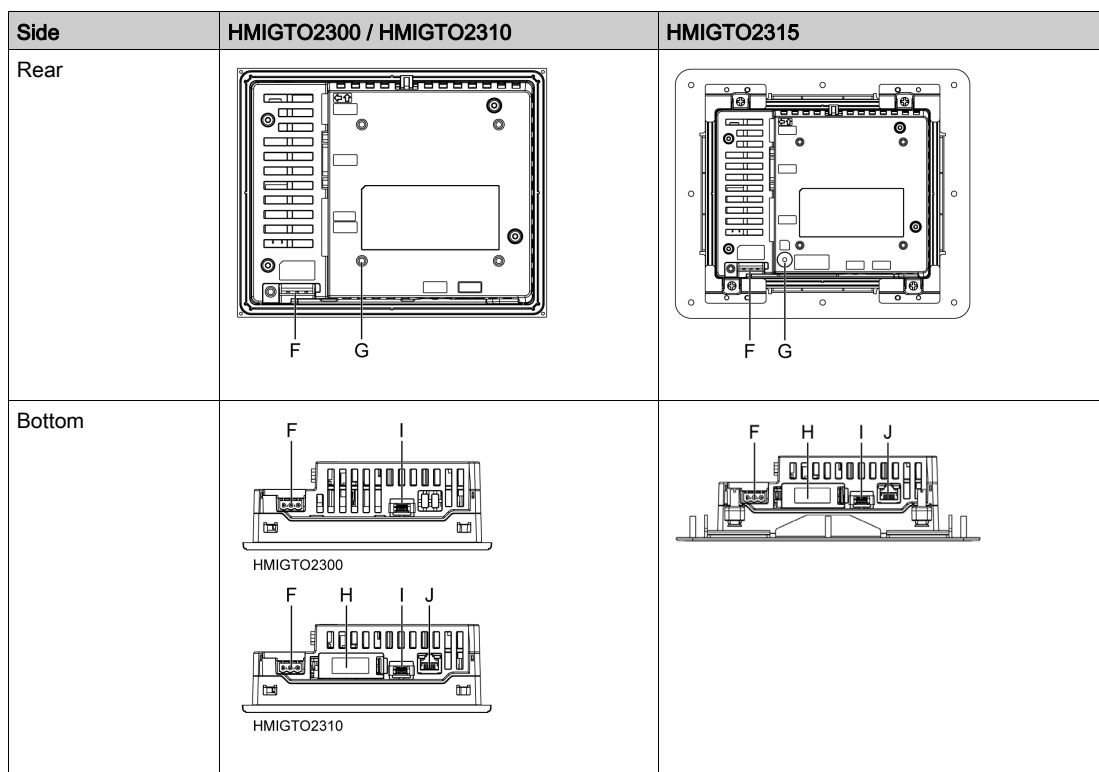

Part	Name	Description
A	Status LED	*1
B	Stainless Steel Bezel (grade 304)	HMIGTO2315 only.
C	USB (Type A) Interface	Conforms to USB2.0 (Type A) x 1. Power supply voltage: 5 Vdc+/-5%. Output Current: 500 mA or less. Maximum communication distance: 5 m (16.4 ft).
D	Serial Interface (COM1)	RS-232C Serial Interface. Connector: D-Sub 9 pin (plug) x 1.
E	Serial Interface (COM2)*2	RS-485 Serial Interface. Connector: Modular jack (RJ45).
F	Power Plug Connector	-
G	SD Card Access LED*3	This lamp lights up when SD card is inserted. For more information, refer to SD Card Insertion/Removal (see page 119). NOTE: SD card access LED is not available on HMIGTO2300.
H	SD Card Interface Cover/Replacement Battery Insertion Cover	For information on how to open the cover, and insert or remove the SD card, refer to SD Card Insertion/Removal (see page 119). For information on how to open the cover and replace the battery, refer to Replacing the Primary Battery (see page 134). NOTE: This cover is not on HMIGTO2300.
I	USB (mini-B) Interface	Conforms to USB2.0 (mini-B) x 1. Communication Distance: 5 m (16.4 ft) or less.
J	Ethernet Interface*4	Ethernet transmission interface (10BASE-T/100BASE-TX) Connector: Modular jack (RJ45) x 1. NOTE: Ethernet Interface is not available on HMIGTO2300.

*1 Status LED operations are as shown below:

Color	Indicator	Description
Green	ON	In operation
Orange	Flashing	Software starting up.
Red	ON	Power is turned ON.
-	OFF	Power is turned OFF.

*2 COM2 LED operations are as shown below.

Color	Indicator	Description
Yellow	ON	Communication (sending or receiving data) is occurring.
	OFF	No communication.

*3 SD card access LED operations are as shown below.

Color	Indicator	Description
Green (Active)	ON	The SD card is inserted.
	OFF	The SD card is not inserted or is not being accessed.

*4 Ethernet LED operations are as shown below.

	Color	Indicator	Description
 Link Active	Green (Active)	Flashing	Data transmission is occurring.
		OFF	No data transmission.
	Green (Link)	ON	Data transmission is available in 10BASE-T/100BASE-TX.
		OFF	No connection or subsequent transmission failure.

HMIGTO3510/4310 Parts Identification

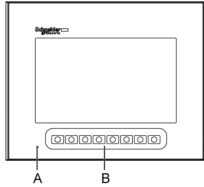
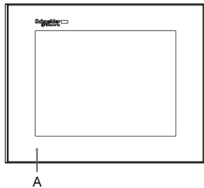
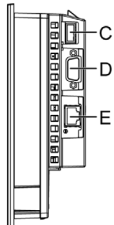
Side	HMIGTO3510/4310
Front	<p>HMIGTO3510</p>  <p>A B</p> <p>HMIGTO4310</p>  <p>A</p>
Right	 <p>C D E</p>

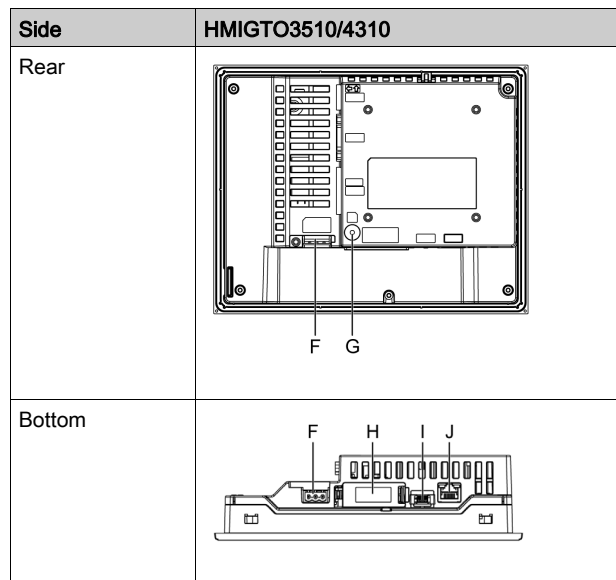

Part	Name	Description
A	Status LED	*1
B	Function Switches	Height switches (F1 to F8). You can define operations for these switches using EcoStruxure Operator Terminal Expert.
C	USB (Type A) Interface	Conforms to USB2.0 (Type A) x 1. Power supply voltage: 5 Vdc+/-5%. Output Current: 500 mA or less. Maximum communication distance: 5 m (16.4 ft).
D	Serial Interface (COM1)	RS-232C Serial Interface. Connector: D-Sub 9 pin (plug) x 1.
E	Serial Interface (COM2)*2	RS-485 Serial Interface. Connector: Modular jack (RJ45) x 1.
F	Power Plug Connector	-
G	SD Card Access LED*3	This lamp lights up when SD card is inserted. For more information, refer to SD Card Insertion/Removal (see page 119).
H	SD Card Interface Cover/Replacement Battery Insertion Cover	For information on how to open the cover, and insert or remove the SD card, refer to SD Card Insertion/Removal (see page 119). For information on how to open the cover and replace the battery, refer to Replacing the Primary Battery (see page 134).
I	USB (mini-B) Interface	Conforms to USB2.0 (mini-B) x 1. Communication Distance: 5 m (16.4 ft) or less.
J	Ethernet Interface*4	Ethernet transmission interface (10BASE-T/100BASE-TX) Connector: Modular jack (RJ45) x 1.

*1 Status LED operations are as shown below:

Color	Indicator	Description
Green	ON	In operation
Orange	Flashing	Software starting up.
Red	ON	Power is turned ON.
-	OFF	Power is turned OFF.

*2 COM2 LED operations are as shown below.

Color	Indicator	Description
Yellow	ON	Communication (sending or receiving data) is occurring.
	OFF	No communication.

*3 SD card Access LED operations are as shown below.

Color	Indicator	Description
Green (Active)	ON	The SD card is inserted.
	OFF	The SD card is not inserted or is not being accessed.

*4 Ethernet LED operations are as shown below.

	Color	Indicator	Description
 Link Active	Green (Active)	Flashing	Data transmission is occurring.
		OFF	No data transmission.
	Green (Link)	ON	Data transmission is available in 10BASE-T/100BASE-TX.
		OFF	No connection or subsequent transmission failure.

HMIGTO5310/5315 Parts Identification

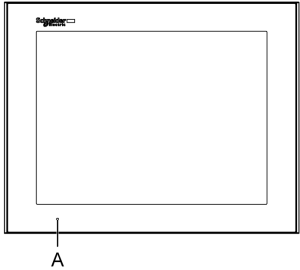
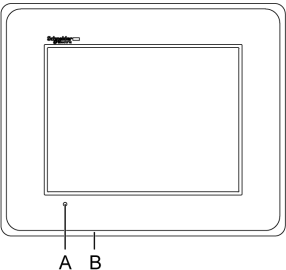
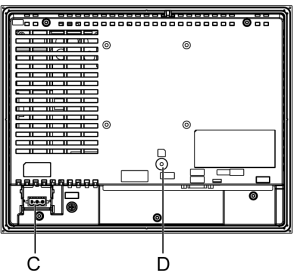
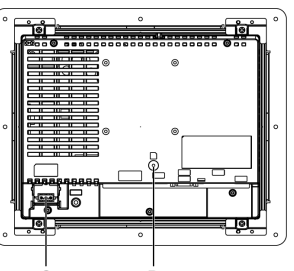
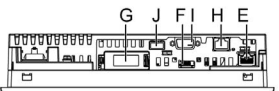
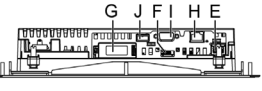
Side	HMIGTO5310	HMIGTO5315
Front		
Rear		
Bottom		

Part	Name	Description
A	Status LED	*1
B	Stainless Steel Bezel (grade 304)	HMIGTO5315 only.
C	Power Plug Connector (DC model)	-
D	SD Card Access LED *2	This lamp lights up when SD card is inserted. NOTE: Do not remove or insert the SD card when the LED lamp is on. Doing so may damage data on the SD card.
E	Ethernet Interface *3	Ethernet transmission interface (10BASE-T/100BASE-TX) Connector: Modular jack (RJ45) x 1.
F	USB (mini-B) Interface	Conforms to USB2.0 (mini-B) x 1. Communication Distance: 5 m (16.4 ft) or less.

Part	Name	Description
G	SD Card Interface Cover/Replacement Battery Insertion Cover	For information on how to open the cover, and insert or remove the SD card, refer to SD Card Insertion/Removal (<i>see page 119</i>). For information on how to open the cover and replace the battery, refer to Replacing the Primary Battery (<i>see page 134</i>).
H	Serial Interface (COM2)*4	RS-485 Serial Interface. Connector: Modular jack (RJ45).
I	Serial Interface (COM1)	RS-232C Serial Interface. Connector: D-Sub 9 pin (plug) x 1.
J	USB (Type A) Interface	Conforms to USB2.0 (Type A) x 1. Power supply voltage: 5 Vdc+/-5%. Output Current: 500 mA or less. Maximum communication distance: 5 m (16.4 ft).

*1 Status LED operations are as shown below:

Color	Indicator	Description
Green	ON	In operation
Orange	Flashing	Software starting up.
Red	ON	Power is turned ON.
-	OFF	Power is turned OFF.

*2 SD card access LED operations are as shown below.

Color	Indicator	Description
Green (Active)	ON	The SD card is inserted.
	OFF	The SD card is not inserted or is not being accessed.

*3 Ethernet LED operations are as shown below.

	Color	Indicator	Description
 Link Active	Green (Active)	Flashing	Data transmission is occurring.
		OFF	No data transmission.
	Green (Link)	ON	Data transmission is available in 10BASE-T/100BASE-TX.
		OFF	No connection or subsequent transmission failure.

*4 COM2 LED operations are as shown below.

Color	Indicator	Description
Yellow	ON	Communication (sending or receiving data) is occurring.
	OFF	No communication.

HMIGTO6310/6315 Parts Identification

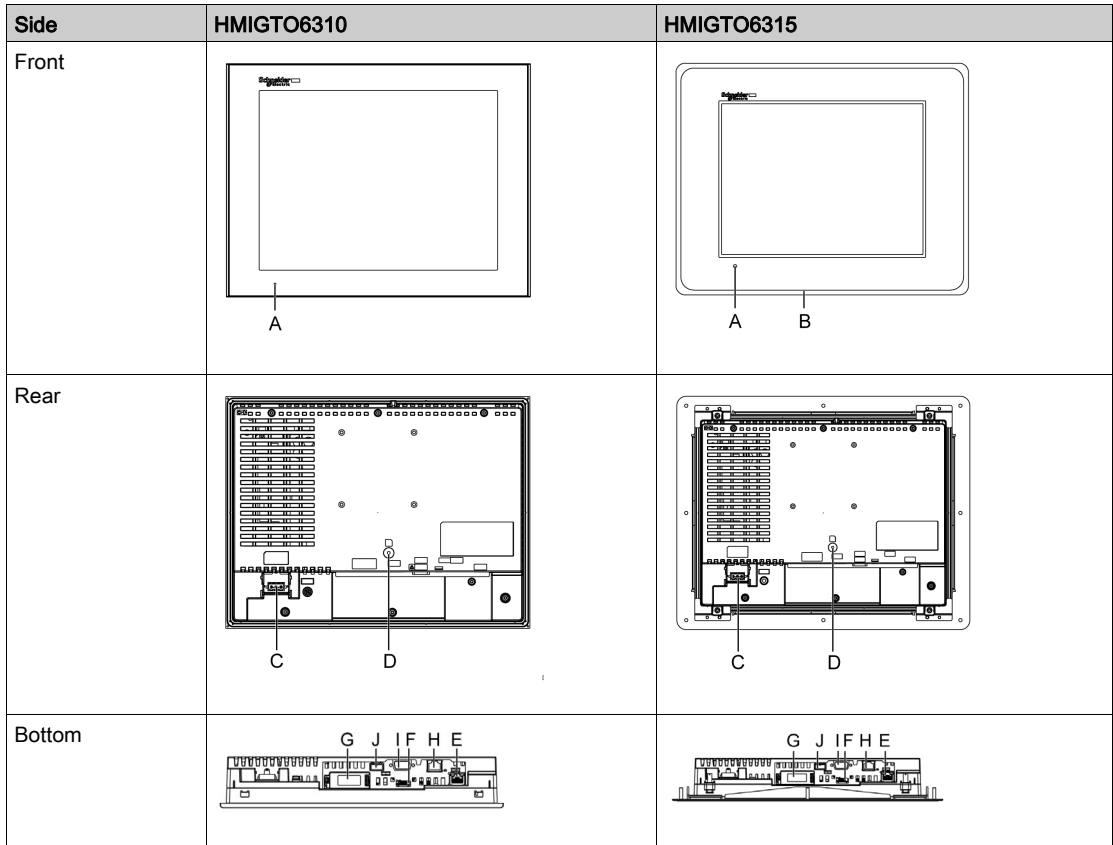

Part	Name	Description
A	Status LED	*1
B	Stainless Steel Bezel (grade 304)	HMIGTO6315 only.
C	Power Plug Connector (DC model)	-
D	SD Card Access LED*2	This lamp lights up when SD card is inserted. NOTE: Do not remove or insert the SD card when the LED lamp is on. Doing so may damage data on the SD card.
E	Ethernet Interface*3	Ethernet transmission interface (10BASE-T/100BASE-TX) Connector: Modular jack (RJ45) x 1.
F	USB (mini-B) Interface	Conforms to USB2.0 (mini-B) x 1. Communication Distance: 5 m (16.4 ft) or less.
G	SD Card Interface Cover/Replacement Battery Insertion Cover	For information on how to open the cover, and insert or remove the SD card, refer to SD Card Insertion/Removal (see page 119). For information on how to open the cover and replace the battery, refer to Replacing the Primary Battery (see page 134).
H	Serial Interface (COM2)*4	RS-485 Serial Interface. Connector: Modular jack (RJ45)
I	Serial Interface (COM1)	RS-232C Serial Interface. Connector: D-Sub 9 pin (plug) x 1.
J	USB (Type A) Interface	Conforms to USB2.0 (Type A) x 1. Power supply voltage: 5 Vdc+/-5%. Output Current: 500 mA or less. Maximum communication distance: 5 m (16.4 ft).

*1 Status LED operations are as shown below:

Color	Indicator	Description
Green	ON	In operation
Orange	Flashing	Software starting up.
Red	ON	Power is turned ON.
-	OFF	Power is turned OFF.

*2 SD card access LED operations are as shown below.

Color	Indicator	Description
Green (Active)	ON	The SD card is inserted.
	OFF	The SD card is not inserted or is not being accessed.

*3 Ethernet LED operations are as shown below.

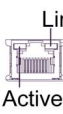
	Color	Indicator	Description
 Link Active	Green (Active)	Flashing	Data transmission is occurring.
		OFF	No data transmission.
	Green (Link)	ON	Data transmission is available in 10BASE-T/100BASE-TX.
		OFF	No connection or subsequent transmission failure.

*4 COM2 LED operations are as shown below.

Color	Indicator	Description
Yellow	ON	Communication (sending or receiving data) is occurring.
	OFF	No communication.

Chapter 4

Specifications

Overview

This chapter presents the HMIGTO specifications.

What Is in This Chapter?

This chapter contains the following sections:

Section	Topic	Page
4.1	HMIGTO1300/1310	34
4.2	HMIGTO2300/2310/2315	47
4.3	HMIGTO3510/4310	62
4.4	HMIGTO5310/5315	76
4.5	HMIGTO6310/6315	91

Section 4.1

HMIGTO1300/1310

What Is in This Section?

This section contains the following topics:

Topic	Page
Electrical Specifications	35
Environmental Specifications	36
Structural Specifications	37
Display Specifications	38
Memory, Clock, Touch Panel, and Function Switches	39
Interface Specifications	40
Specifications of Serial Interface COM1	41
Specifications of Serial Interface COM2	43
Dimensions	44

Electrical Specifications

Power Supply	Rated Input Voltage	24 Vdc	
	Input Voltage Limits	19.2...28.8 Vdc	
	Voltage Drop	2 ms or less	
	Power Consumption	9.6 W or less	
		When power is not supplied to external devices	5.2 W or less
		Backlight Dimmed (Brightness: 20%)	4.3 W or less
	In-Rush Current	30 A or less	
	Voltage Endurance	1,000 Vac 20 mA for 1 minute (between charging and FG terminals)	
	Insulation Resistance	500 Vdc, 10 M Ω or more (between charging and FG terminals)	

Environmental Specifications

Physical Environment	Surrounding Air Temperature	0...50 °C (32...122 °F)
	Storage Temperature	-20...60 °C (-4...140 °F)
	Surrounding Air and Storage Humidity	10%...90% RH (Non-condensing, wet bulb temperature 39 °C (102.2 °F) or less)
	Dust	0.1 mg/m ³ (10 ⁻⁷ oz/ft ³) or less (non-conductive levels)
	Pollution Degree	For use in Pollution Degree 2 environment
	Corrosive Gases	Free of corrosive gases
	Atmospheric Pressure (Operating Altitude)	800...1,114 hPa (2,000 m (6,561 ft) or lower)
Mechanical Environment	Vibration Resistance	IEC/EN 61131-2 compliant 5...9 Hz Single amplitude 3.5 mm (0.14 in) 9...150 Hz Fixed acceleration: 9.8 m/s ² X, Y, Z directions for 10 cycles (approx. 100 min)
	Concussion Resistance	IEC/EN 61131-2 compliant 147 m/s ² , X, Y, Z directions for three times
Electrical Environment	Noise immunity	Noise Voltage: 1,000 Vpp Pulse Width: 1 µs Rise Time: 1 ns (via noise simulator)
	Electrostatic Discharge Immunity	Contact Discharge Method: 6 kV (IEC/EN 61000-4-2 Level 3)

Air Quality Requirements

Do not operate or store the panel where chemicals evaporate, or where chemicals are present in the air:

- Corrosive chemicals: Acids, alkalines, liquids containing salt.
- Flammable chemicals: Organic solvents.

 CAUTION
INOPERATIVE EQUIPMENT
Do not allow water, liquids, metal, and wiring fragments to enter the panel case.
Failure to follow these instructions can result in injury or equipment damage.

Structural Specifications

Grounding	Functional grounding: Grounding resistance of 100 Ω , 2 mm ² (AWG 14) or thicker wire, or your country's applicable standard. (Same for FG and SG terminals)
Cooling Method	Natural air circulation
Structure ^{*1}	IP65f NEMA #250 TYPE 4X/13 (on the front panel when properly installed in an enclosure)
External Dimensions	W 132 x H 106 x D 42 mm (W 5.2 x H 4.17 x D 1.65 in)
Panel Cut Dimensions	W 118.5 x H 92.5 mm (W 4.67 x H 3.64 in) ^{*2} Panel thickness area: 1.6...5 mm (0.06...0.2 in) ^{*3}
Weight	0.4 kg (0.9 lb) or less (main unit only)

^{*1} The front face of the HMIGTO, installed in a solid panel, has been tested using conditions equivalent to the standards shown in the specification. Even though the HMIGTO's level of resistance is equivalent to these standards, oils that should have no effect on the HMIGTO can possibly harm the panel. This can occur in areas where either vaporized oils are present, or where low viscosity cutting oils are allowed to adhere to the panel for long periods of time. If the panel's front face protection sheet peels off, these conditions can lead to the ingress of oil into the panel and separate protection measures are suggested.

Also, if non-approved oils are present, they may cause deformation or corrosion of the front panel's plastic cover. Therefore, prior to installing the panel, be sure to confirm the type of conditions that will be present in the panel's operating environment. If the installation gasket is used for a long period of time, or if the panel and its gasket are removed from the panel, the original level of protection cannot be kept. To maintain the original protection level, be sure to replace the installation gasket regularly.

^{*2} For dimensional tolerance, everything +1/-0 mm (+0.04/-0 in), and R in angle are below R3 (R0.12 in)

^{*3} Even if the installation wall thickness is within the recommended range for the "Panel Cut Dimensions", depending on wall's material, size, and installation location of the panel and other devices, the installation wall could warp. To prevent warping, the installation surface may need to be strengthened.

The front face of the panel, installed in a solid panel, has been tested using conditions equivalent to the standards shown in the specification.

CAUTION

EQUIPMENT DAMAGE

Ensure that the panel is not in permanent and direct contact with oils.

Failure to follow these instructions can result in injury or equipment damage.

NOTICE

STORAGE AND OPERATION OUTSIDE OF SPECIFICATIONS

- Store this product in areas where temperatures are within the product's specifications.
- Do not restrict or block this product's ventilation slots.

Failure to follow these instructions can result in equipment damage.

NOTICE

GASKET AGING

- Inspect the gasket periodically as required by your operating environment to keep the initial IP level.
- Change the gasket at least once a year, or as soon as scratches or dirt become visible.

Failure to follow these instructions can result in equipment damage.

Display Specifications

Display Type	TFT Color LCD
Display Size	3.5"
Resolution	320 x 240 pixels (QVGA)
Effective Display Area	W 70.56 x H 52.92 mm (W 2.78 x H 2.08 in)
Display Colors	65,536 colors
Backlight	White LED (Not user replaceable. When replacement is required, contact your local distributor.)
Backlight Service Life	50,000 hours or more (continuous operation at 25 °C (77 °F) before backlight brightness decreased to 50%)
Brightness Control	16 levels (Adjusted with touch panel or software)

Memory, Clock, Touch Panel, and Function Switches

Introduction

NOTE:

- When the message indicating that the battery level is low is displayed, supply power to the panel and fully charge the battery. In 24 hours the battery charges to a level that allows backup operation. Completing a full charge requires about 120 hours (five days).
- The lifetime of the rechargeable lithium battery is 10 years when the battery's ambient temperature is 40 °C (104 °F) or less, 4.1 years when the battery's ambient temperature is 50 °C (122 °F) or less, and 1.5 years when the battery's ambient temperature is 60 °C (140 °F) or less.
When used for backup:
 - Approximately 100 days with a fully charged battery.
 - Approximately 6 days with a half-charged battery.

Memory

	HMIGTO1310	HMIGTO1300
System Memory	Flash EPROM 128 MB (operating system, project data, and other data)	
Backup Memory	SRAM 512 KB (rechargeable lithium battery for data backup)	SRAM 128 KB (rechargeable lithium battery for data backup)

Clock

Clock Accuracy*1	±65 seconds/month (deviation at room temperature and power is OFF).
------------------	---

*1 Depending on the operating temperature and age of panel, the clock can deviate from -380 to +90 sec/month. For systems where this level of precision is insufficient, the user should monitor and make adjustments when required.

Touch Panel

Touch Panel Type	Resistive Film (analog)
Touch Panel Resolution	1,024 x 1,024
Touch Panel Service Life	1 million times or more

Function Switches

Six switches (F1 to F6).

Interface Specifications

Serial Interface COM1

	HMIGTO1310	HMIGTO1300
Asynchronous Transmission	RS-232C / RS-485	RS-232C
Data Length	7 bits or 8 bits	
Stop Bit	1 bit or 2 bits	
Parity	None, odd or even	
Data Transmission Speed	2,400...115,200 bps, 187,500 bps (MPI)	2,400...115,200 bps
Connector	Modular jack (RJ45)	D-Sub 9 pin (plug)

Serial Interface COM2

	HMIGTO1300
Asynchronous Transmission	RS-485
Data Length	7 bits or 8 bits
Stop Bit	1 bit or 2 bits
Parity	None, odd or even
Data Transmission Speed	2,400...115,200 bps, 187,500 bps (MPI)
Connector	Modular jack (RJ45)

USB Interface

	USB (Type A) Interface	USB (mini-B) Interface
Connector	USB 2.0 (Type A) x 1	USB 2.0 (mini-B) x 1
Power Supply Voltage	5 Vdc ±5%	-
Maximum Current Supplied	500 mA	-
Maximum Transmission Distance	5 m (16.4 ft)	

Ethernet Interface

	HMIGTO1310
Ethernet (LAN)	IEEE802.3i / IEEE802.3u, 10BASE-T/100BASE-TX
Connector	Modular jack (RJ45) x 1

NOTE: HMIGTO1300 does not have an Ethernet interface.

Specifications of Serial Interface COM1

Introduction

NOTE: For information on how to connect controllers and other types of equipment, refer to the corresponding device driver manual of your screen editing software.

⚠ CAUTION

LOSS OF COMMUNICATION

- All connections to the communication ports must not put excessive stress on the ports.
- Securely attach communication cables to the panel or cabinet.
- Use only D-Sub 9-pin cables with a locking system in good condition.

Failure to follow these instructions can result in injury or equipment damage.

The serial port is not isolated. The SG (signal ground) and FG (frame ground) terminals are connected inside the panel.

⚠ ⚠ DANGER

ELECTRIC SHOCK

When using the SG terminal to connect an external device to the panel:

- Verify that a short-circuit loop is not created when you set up the system.
- For HMIGTO1300, connect the #5 SG terminal to remote equipment when the host (PLC) unit is not isolated. Connect the #5 SG terminal to a known reliable ground connection to reduce the risk of damaging the circuit.
- For HMIGTO1310, connect the #8 SG terminal to remote equipment when the host (PLC) unit is not isolated. Connect the #8 SG terminal to a known reliable ground connection to reduce the risk of damaging the circuit.

Failure to follow these instructions will result in death or serious injury.

Serial Interface COM1

HMIGTO1300: D-Sub 9-pin plug connector via a RS-232C cable.

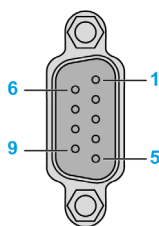
Pin Connection	Pin No.	RS-232C		
		Signal Name	Direction	Meaning
	1	CD	Input	Carrier Detect
	2	RD(RXD)	Input	Receive Data
	3	SD(TXD)	Output	Send Data
	4	ER(DTR)	Output	Data Terminal Ready
	5	SG	-	Signal Ground
	6	DR(DSR)	Input	Data Set Ready
	7	RS(RTS)	Output	Request to Send
	8	CS(CTS)	Input	Send possible
	9	CI(RI)/VCC	Input-	Called Status Display +5 V±5% Output 0.25 A
	Shell	FG	-	Frame Ground (Common with SG)

You can switch pin #9 between RI and VCC via software.

NOTICE

EQUIPMENT DAMAGE

Use only the rated current.

Failure to follow these instructions can result in equipment damage.

Interfit bracket is #4-40 (UNC).

⚠ CAUTION
<p>LOSS OF COMMUNICATION</p> <ul style="list-style-type: none"> ● All connections to the communication ports must not put excessive stress on the ports. ● Securely attach communication cables to the panel wall or cabinet. ● Use only D-Sub 9 pin cables with a locking tab in good condition. <p>Failure to follow these instructions can result in injury or equipment damage.</p>

HMIGTO1310: RJ45 connector via a RS-232C or 485 cable.

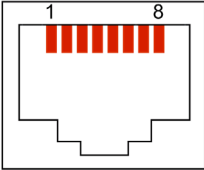
Pin Connection	Pin No.	RS-232C/RS-485		
		Signal Name	Direction	Meaning
	1	RD(RXD)	Input	Receive Data (RS-232C)
	2	SD(TXD)	Output	Send Data (RS-232C)
	3	NC	-	-
	4	D1	Input/Output	Transfer Data (RS-485)
	5	D0	Input/Output	Transfer Data (RS-485)
	6	RS(RTS)	Output	Request to Send
	7	NC	-	-
	8	SG	-	Signal Ground

⚠ CAUTION
<p>LOSS OF COMMUNICATION</p> <ul style="list-style-type: none"> ● All connections to the communication ports must not put excessive stress on the ports. ● Securely attach communication cables to the panel wall or cabinet. ● Use only RJ45 with a locking tab in good condition. <p>Failure to follow these instructions can result in injury or equipment damage.</p>

Specifications of Serial Interface COM2

Introduction

NOTE: For information on how to connect controllers and other types of equipment, refer to the corresponding device driver manual of your screen editing software.

The serial port is not isolated. The SG (signal ground) and FG (frame ground) terminals are connected inside the panel.

DANGER

ELECTRIC SHOCK

When using the SG terminal to connect an external device to the panel:

- Verify that a short-circuit loop is not created when you set up the system.
- Connect the #8 SG terminal to remote equipment when the host (PLC) unit is not isolated. Connect the #8 SG terminal to a known reliable ground connection to reduce the risk of damaging the circuit.

Failure to follow these instructions will result in death or serious injury.

Serial Interface COM2

HMIGTO1300: RJ45 connector via an RS-485 cable

NOTE: When setting up RS-485 communication, the cable diagram for some equipment may require polarization on the terminal side. This terminal does not require any special setting as it handles polarization automatically.

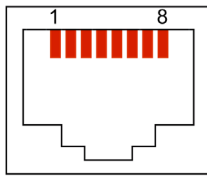
Pin Connection	Pin No.	RS-485		
		Signal Name	Direction	Meaning
	1	NC	–	–
	2	NC	–	–
	3	NC	–	–
	4	Line A	Input/Output	Transfer Data (RS-485)
	5	Line B	Input/Output	Transfer Data (RS-485)
	6	RS(RTS)	Output	Request to Send
	7	NC	–	–
	8	SG	–	Signal Ground

CAUTION

LOSS OF COMMUNICATION

- All connections to the communication ports must not put excessive stress on the ports.
- Securely attach communication cables to the panel wall or cabinet.
- Use only RJ45 with a locking tab in good condition.

Failure to follow these instructions can result in injury or equipment damage.

Dimensions

External Dimensions

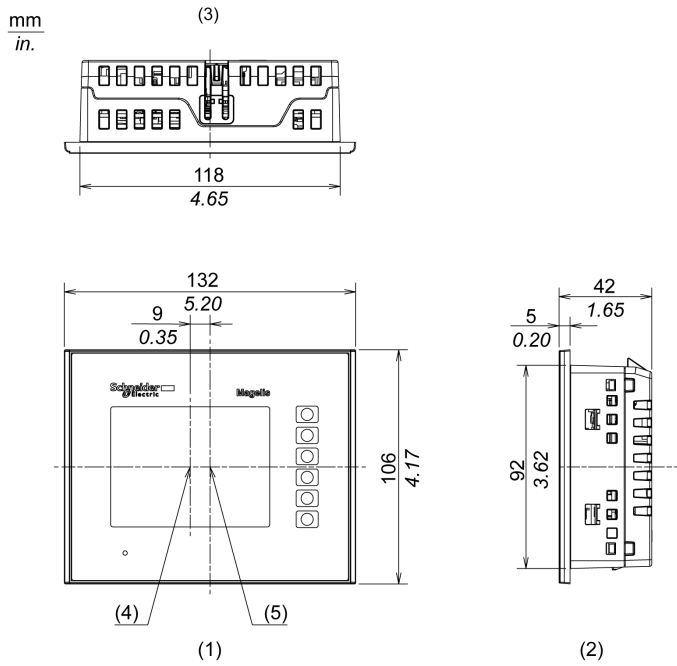

- 1 Front
- 2 Right side
- 3 Top
- 4 Display area center
- 5 Product center

Installation with Installation Fasteners

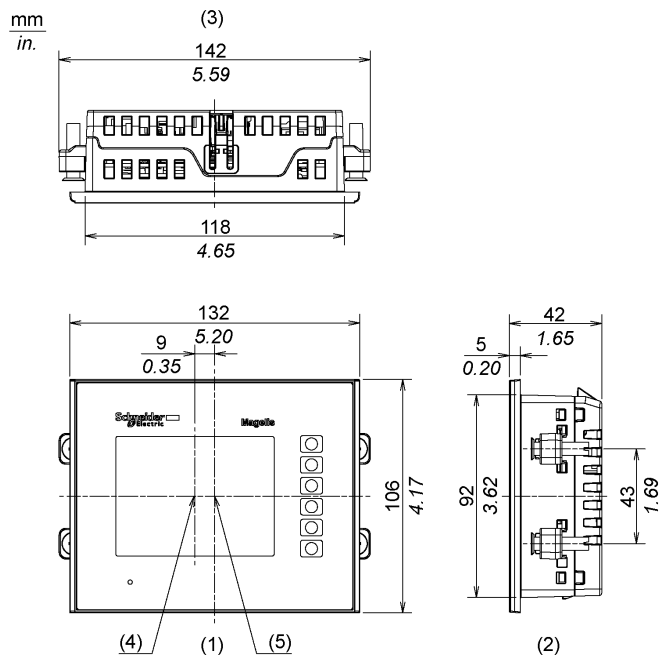

- 1 Front
- 2 Right side
- 3 Top
- 4 Display area center
- 5 Product center

Dimensions with Cables: HMIGTO1300

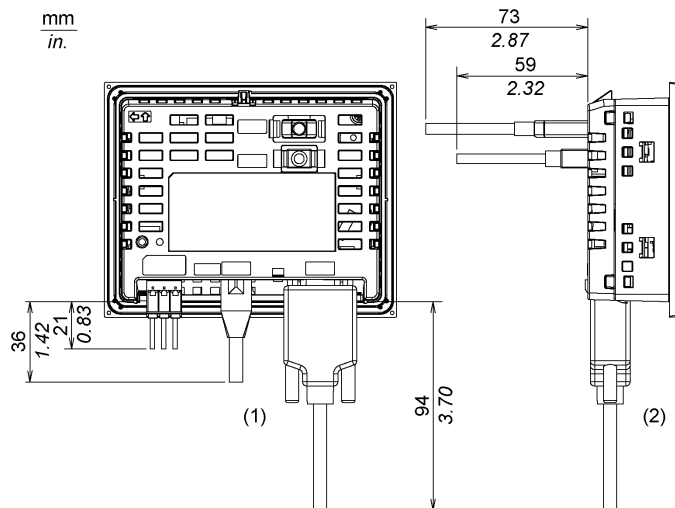

- 1 Rear
- 2 Right side

NOTE: All the above values are designed with cable bending in mind. The dimensions given here are representative values depending on the type of connection cable in use. Therefore, these values are intended for reference only.

Dimensions with Cables: HMIGTO1310

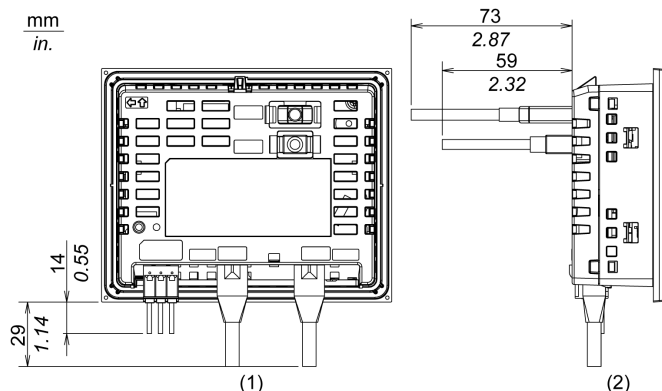

- 1 Rear
- 2 Right side

NOTE: All the above values are designed with cable bending in mind. The dimensions given here are representative values depending on the type of connection cable in use. Therefore, these values are intended for reference only.

Panel Cut Dimensions

Create a panel cut and insert the panel into the opening from the front.

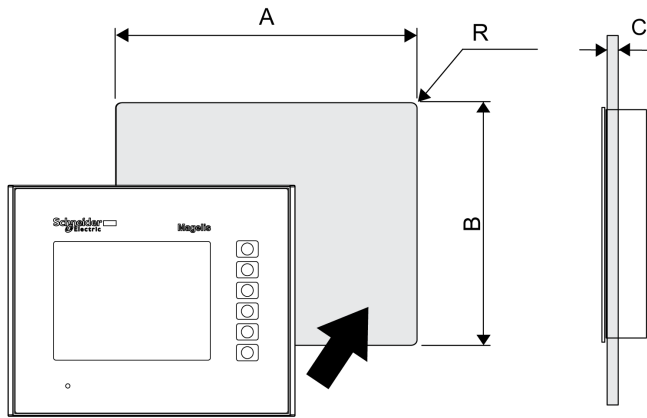

A	B	C	R
118.5 mm (+1, -0 mm) (4.67 in (+0.04, -0 in))	92.5 mm (+1, -0 mm) (3.64 in (+0.04, -0 in))	1.6...5 mm (0.06...0.2 in)	3 mm (0.12 in) maximum

NOTE: Before designing the panel cut, refer to Installation.

Installation Fastener Dimensions

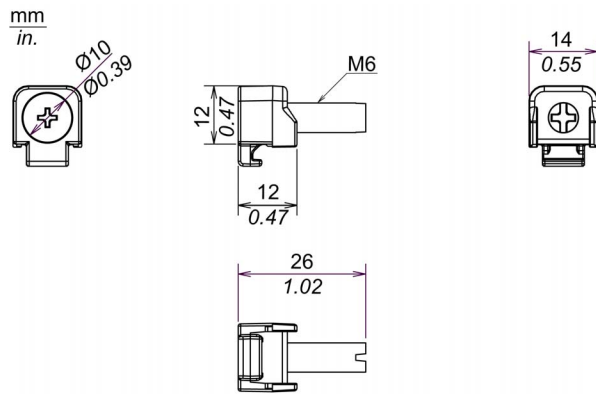

Section 4.2

HMIGTO2300/2310/2315

What Is in This Section?

This section contains the following topics:

Topic	Page
Electrical Specifications	48
Environmental Specifications	49
Structural Specifications	50
Display Specifications	52
Memory, Clock, and Touch Panel	53
Interface Specifications	54
Specifications of Serial Interface COM1	55
Specifications of Serial Interface COM2	57
Dimensions	58

Electrical Specifications

Power Supply	Rated Input Voltage	24 Vdc	
	Input Voltage Limits	19.2...28.8 Vdc	
	Voltage Drop	5 ms or less	
	Power Consumption	10.5 W or less	
		When power is not supplied to external devices	6.5 W or less
		Backlight Dimmed (Brightness: 20%)	5 W or less
	In-Rush Current	30 A or less	
Voltage Endurance		1,000 Vac, 20 mA for 1 minute (between charging and FG terminals)	
Insulation Resistance		500 Vdc, 10 M Ω or more (between charging and FG terminals)	

Environmental Specifications

		HMIGTO2310 / HMIGTO2315	HMIGTO2300
Physical Environment	Surrounding Air Temperature	0...55 °C (32 °F...131 °F)	0...50 °C (32...122 °F)
	Storage Temperature	-20...60 °C (-4...140 °F)	
	Surrounding Air and Storage Humidity	10...90% RH (Non-condensing, wet bulb temperature 39 °C (102.2 °F) or less)	
	Dust	0.1 mg/m ³ (10 ⁻⁷ oz/ft ³) or less (non-conductive levels)	
	Pollution Degree	For use in Pollution Degree 2 environment	
	Corrosive Gases	Free of corrosive gases	
	Atmospheric Pressure (Operating Altitude)	800...1,114 hPa (2,000 m (6,561 ft) or lower)	
Mechanical Environment	Vibration Resistance	IEC/EN 61131-2 compliant 5...9 Hz Single amplitude 3.5 mm (0.14 in) 9...150 Hz Fixed acceleration: 9.8 m/s ² X, Y, Z directions for 10 cycles (approx. 100 min)	
	Concussion Resistance	IEC/EN 61131-2 compliant 147 m/s ² , X, Y, Z directions for three times	
Electrical Environment	Noise Immunity	Noise Voltage: 1,000 Vpp Pulse Width: 1 µs Rise Time: 1 ns	
	Electrostatic Discharge Immunity	Contact Discharge Method: 6 kV (IEC/EN 61000-4-2 Level 3)	

Air Quality Requirements

Do not operate or store the panel where chemicals evaporate, or where chemicals are present in the air:

- Corrosive chemicals: Acids, alkalines, liquids containing salt.
- Flammable chemicals: Organic solvents.

CAUTION

INOPERATIVE EQUIPMENT

Do not allow water, liquids, metal, and wiring fragments to enter the panel case.

Failure to follow these instructions can result in injury or equipment damage.

Structural Specifications

	HMIGTO2300 / HMIGTO2310	HMIGTO2315
Grounding	Functional grounding: Grounding resistance of 100 Ω, 2mm ² (AWG 14) or thicker wire, or your country's applicable standard. (Same for FG and SG terminals)	
Cooling Method	Natural air circulation	
Structure ^{*1}	IP65f NEMA #250 TYPE 4X/13 (on the front panel when properly installed in an enclosure)	IP66k NEMA #250 TYPE 4X/13 (on the front panel when properly installed in an enclosure) ^{*2}
External Dimensions	W 169.5 x H 137 x D 59.5 mm (W 6.67 x H 5.39 x D 2.34 in)	W 213.5 x H 181 x D 59.5 mm (W 8.41 x H 7.13 x D 2.34 in)
Panel Cut Dimensions	W 156 x H 123.5 mm (W 6.14 x H 4.86 in) ^{*3} Panel thickness area: 1.6...5 mm (0.06...0.2 in) ^{*4}	W 195 x H 162.5 mm (W 7.68 x H 6.40 in) ^{*3} Panel thickness area: 1.6...5 mm (0.06...0.2 in) ^{*4}
Weight	0.8 kg (1.8 lbs) or less (main unit only)	1.2 kg (2.6 lbs) or less (main unit only)

NOTE: ^{*1} The front face of the HMIGTO, installed in a solid panel, has been tested using conditions equivalent to the standards shown in the specification. Even though the HMIGTO's level of resistance is equivalent to these standards, oils that should have no effect on the HMIGTO can possibly harm the panel. This can occur in areas where either vaporized oils are present, or where low viscosity cutting oils are allowed to adhere to the panel for long periods of time. If the panel's front face protection sheet peels off, these conditions can lead to the ingress of oil into the panel and separate protection measures are suggested.

Also, if non-approved oils are present, they may cause deformation or corrosion of the front panel's plastic cover. Therefore, prior to installing the panel, be sure to confirm the type of conditions that will be present in the panel's operating environment. If the installation gasket is used for a long period of time, or if the panel and its gasket are removed from the panel, the original level of protection cannot be kept. To maintain the original protection level, be sure to replace the installation gasket regularly.

^{*2} When installing the HMIGTO in a panel, you may not be able to mount the HMIGTO flush with the panel. This occurs due to the thickness of the gasket. The difference in level between the HMIGTO and panel depends on how much the gasket is compressed.

There is a conformal coating on circuit boards for HMIGTO2315

<i>NOTICE</i>
EQUIPMENT DAMAGE
For food and beverage and pharmaceutical industries, when the HMIGTO is not flush with panel, use silicon to form a seal to prevent water, chemicals, or food from lodging into place.
Failure to follow these instructions can result in equipment damage.

^{*3} For dimensional tolerance, everything +1/-0 mm (+0.04/-0 in) and R in angle are below R3 (R0.12 in).

^{*4} Even if the installation wall thickness is within the recommended range for the "Panel Cut Dimensions", depending on wall's material, size, and installation location of the panel and other devices, the installation wall could warp. To prevent warping, the installation surface may need to be strengthened.

CAUTION
EQUIPMENT DAMAGE
Ensure that the panel is not in permanent and direct contact with oils.
Failure to follow these instructions can result in injury or equipment damage.

NOTICE**STORAGE AND OPERATION OUTSIDE OF SPECIFICATIONS**

- Store this product in areas where temperatures are within the product's specifications.
- Do not restrict or block this product's ventilation slots.

Failure to follow these instructions can result in equipment damage.

NOTICE**GASKET AGING**

- Inspect the gasket periodically as required by your operating environment to keep the initial IP level.
- Change the gasket at least once a year, or as soon as scratches or dirt become visible.

Failure to follow these instructions can result in equipment damage.

Display Specifications

Display Type	TFT Color LCD
Display Size	5.7"
Resolution (pixels)	320 x 240 pixels (QVGA)
Effective Display Area	W 115.2 x H 86.4 mm (W 4.54 x H 3.40 in)
Display Colors	65,536 colors
Backlight	White LED (Not user replaceable. When replacement is required, contact your local distributor.)
Backlight Service Life	50,000 hours or more (continuous operation at 25 °C (77 °F) before backlight decreases to 50%.)
Brightness Control	16 levels (Adjusted with touch panel or software)

Memory, Clock, and Touch Panel

Introduction

NOTE:

- When the message indicating that the battery level is low is displayed, on the HMIGTO2300, supply power to the panel and fully charge the battery. In 24 hours the battery charges to a level that allows backup operation. Completing a full charge requires about 120 hours (five days).
- The lithium battery's lifetime is: 10 years when the battery's ambient temperature is 40 °C (104 °F) or less, 4.1 years when the battery's ambient temperature is 50 °C (122 °F) or less, and 1.5 years when the battery's ambient temperature is 60 °C (140 °F) or less.
When used for backup:
 - Approximately 100 days with a fully charged battery.
 - Approximately 6 days with a half-charged battery.
- When the message indicating that the battery level is low is displayed on HMIGTO2310/2315, replace the battery (*see page 134*).

Memory

	HMIGTO2310 / HMIGTO2315	HMIGTO2300
System Memory	Flash EPROM 128 MB (operating system, project data, and other data)	
Backup Memory	SRAM 512 KB (replaceable lithium battery for data backup)	SRAM 128 KB (rechargeable lithium battery for data backup)

Clock

Clock Accuracy ^{*1}	±65 seconds/month (deviation at room temperature and power is OFF).
------------------------------	---

^{*1} Depending on the operating temperature and age of panel, the clock can deviate from -380 to +90 sec/month. For systems where this level of precision is insufficient, the user should monitor and make adjustments when required.

Touch Panel

Touch Panel Type	Resistive Film (analog)
Touch Panel Resolution	1,024 x 1,024
Touch Panel Service Life	1 million times or more

Interface Specifications

Serial Interface COM1

Asynchronous Transmission	RS-232C
Data Length	7 or 8 bits
Stop Bit	1 or 2 bits
Parity	None, odd or even
Data Transmission Speed	2,400...115,200 bps
Connector	D-Sub 9-pin (plug)

Serial Interface COM2

Asynchronous Transmission	RS-485
Data Length	7 bits or 8 bits
Stop Bit	1 bit or 2 bits
Parity	None, odd or even
Data Transmission Speed	2,400...115,200 bps, 187,500 bps (MPI)
Connector	Modular jack (RJ45)

USB Interface

	USB (Type A) Interface	USB (mini-B) Interface
Connector	USB 2.0 (Type A) x 1	USB 2.0 (mini-B) x 1
Power Supply Voltage	5 Vdc ±5%	-
Maximum Current Supplied	500 mA	-
Maximum Transmission Distance	5 m (16.4 ft)	

Ethernet Interface

	HMIGTO2310 / HMIGTO2315
Ethernet (LAN)	IEEE802.3i / IEEE802.3u, 10BASE-T/100BASE-TX
Connector	Modular jack (RJ45) x 1

SD Card Interface

HMIGTO2310/HMIGTO2315: SD card slot x 1 (maximum 32 GB SD/SDHC Card)

NOTE: HMIGTO2300 does not have a SD card interface.

Specifications of Serial Interface COM1

Introduction

NOTE: For information on how to connect controllers and other types of equipment, refer to the corresponding device driver manual of your screen editing software.

⚠ CAUTION

LOSS OF COMMUNICATION

- All connections to the communication ports must not put excessive stress on the ports.
- Securely attach communication cables to the panel or cabinet.
- Use only D-Sub 9-pin cables with a locking system in good condition.

Failure to follow these instructions can result in injury or equipment damage.

The serial port is not isolated. The SG (signal ground) and FG (frame ground) terminals are connected inside the panel.

⚡ ⚠ DANGER

ELECTRIC SHOCK

When using the SG terminal to connect an external device to the panel:

- Verify that a short-circuit loop is not created when you set up the system.
- Connect the #5 SG terminal to remote equipment when the host (PLC) unit is not isolated. Connect the #5 SG terminal to a known reliable ground connection to reduce the risk of damaging the circuit.

Failure to follow these instructions will result in death or serious injury.

Serial Interface COM1

HMIGTO2300 / HMIGTO2310/ HMIGTO2315: D-Sub 9-pin plug connector via a RS-232C cable.

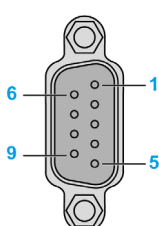
Pin Connection	Pin No.	RS-232C		
		Signal Name	Direction	Meaning
	1	CD	Input	Carrier Detect
	2	RD(RXD)	Input	Receive Data
	3	SD(TXD)	Output	Send Data
	4	ER(DTR)	Output	Data Terminal Ready
	5	SG	-	Signal Ground
	6	DR(DSR)	Input	Data Set Ready
	7	RS(RTS)	Output	Request to Send
	8	CS(CTS)	Input	Send possible
	9	CI(RI)/VCC	Input-	Called Status Display +5 V±5% Output 0.25 A*1
	Shell	FG	-	Frame Ground (Common with SG)

NOTE: *1 You can switch pin number 9 between RI and VCC via software.

NOTICE

EQUIPMENT DAMAGE

Use only the rated current.

Failure to follow these instructions can result in equipment damage.

 **CAUTION**

LOSS OF COMMUNICATION

- All connections to the communication ports must not put excessive stress on the ports.
- Securely attach communication cables to the panel wall or cabinet.
- Use only D-Sub 9 pin cables with a locking tab in good condition.

Failure to follow these instructions can result in injury or equipment damage.

Specifications of Serial Interface COM2

Introduction

NOTE: For information on how to connect controllers and other types of equipment, refer to the corresponding device driver manual of your screen editing software.

The serial port is not isolated. The SG (signal ground) and FG (frame ground) terminals are connected inside the panel.

DANGER

ELECTRIC SHOCK

When using the SG terminal to connect an external device to the panel:

- Verify that a short-circuit loop is not created when you set up the system.
- Connect the #8 SG terminal to remote equipment when the host (PLC) unit is not isolated. Connect the #8 SG terminal to a known reliable ground connection to reduce the risk of damaging the circuit.

Failure to follow these instructions will result in death or serious injury.

Serial Interface COM2

HMIGTO2300 / HMIGTO2310 / HMIGTO2315: RJ45 connector via a RS-485 cable.

NOTE: When setting up RS-485 communication, the cable diagram for some equipment may require polarization on the terminal side. This terminal does not require any special setting as it handles polarization automatically.

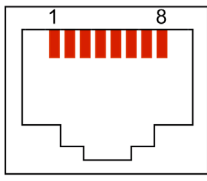
Pin Connection	Pin No.	RS-485		
		Signal Name	Direction	Meaning
	1	NC	-	-
	2	NC	-	-
	3	NC	-	-
	4	Line A	Input/Output	Transfer Data (RS-485)
	5	Line B	Input/Output	Transfer Data (RS-485)
	6	RS(RTS)	Output	Request To Send
	7	NC	-	-
	8	SG	-	Signal Ground

CAUTION

LOSS OF COMMUNICATION

- All connections to the communication ports must not put excessive stress on the ports.
- Securely attach communication cables to the panel wall or cabinet.
- Use only RJ45 with a locking tab in good condition.

Failure to follow these instructions can result in injury or equipment damage.

Dimensions

External Dimensions: HMIGTO2300 / HMIGTO2310

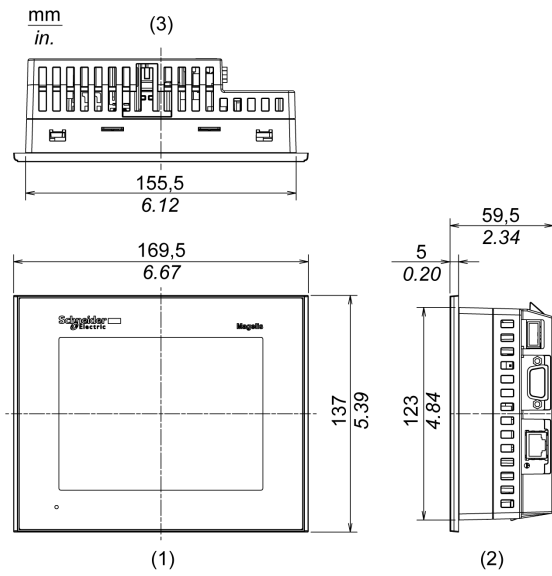

- 1 Front
- 2 Right side
- 3 Top

External Dimensions: HMIGTO2315

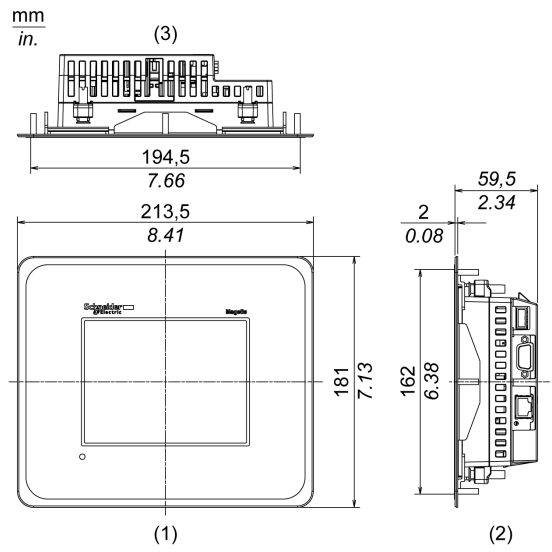

- 1 Front
- 2 Right side
- 3 Top

Installation with Installation Fasteners: HMIGTO2300 / HMIGTO2310

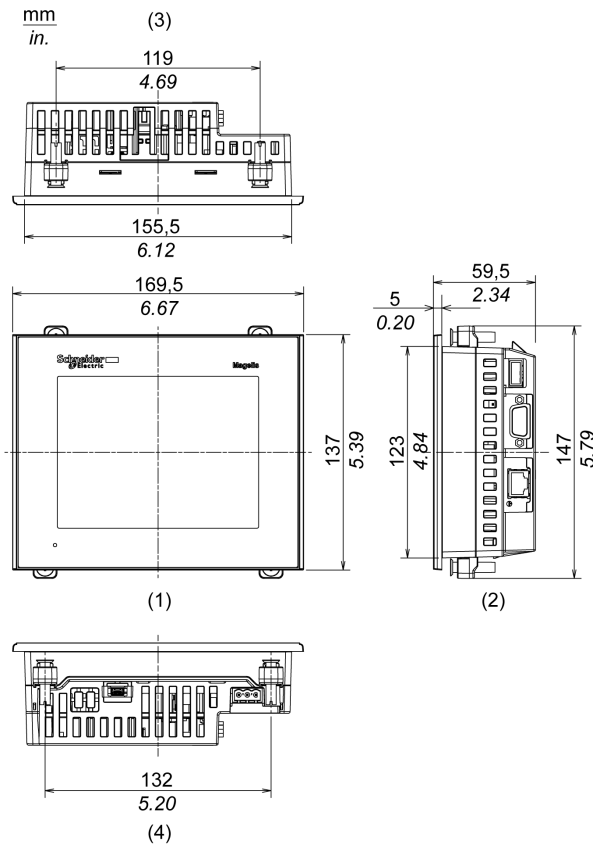

- 1 Front
- 2 Right side
- 3 Top
- 4 Bottom

Installation with Installation Fasteners: HMIGTO2315

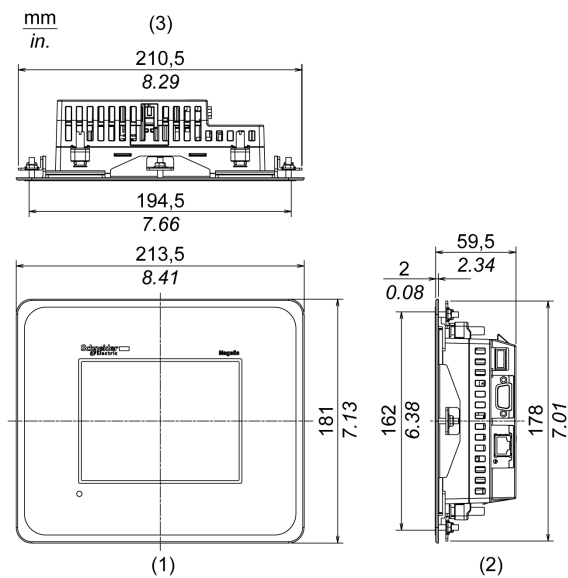

- 1 Front
- 2 Right side
- 3 Top

Dimensions with Cables: HMIGTO2300

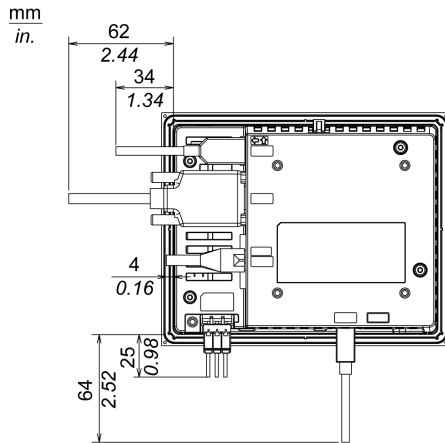

NOTE: All the above values are designed with cable bending in mind. The dimensions given here are representative values depending on the type of connection cable in use. Therefore, these values are intended for reference only.

Dimensions with Cables: HMIGTO2310

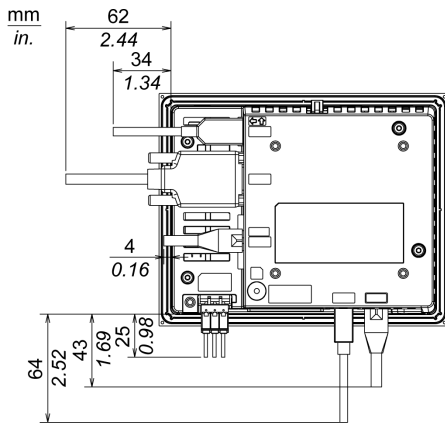

NOTE: All the above values are designed with cable bending in mind. The dimensions given here are representative values depending on the type of connection cable in use. Therefore, these values are intended for reference only.

Dimensions with Cables: HMIGTO2315

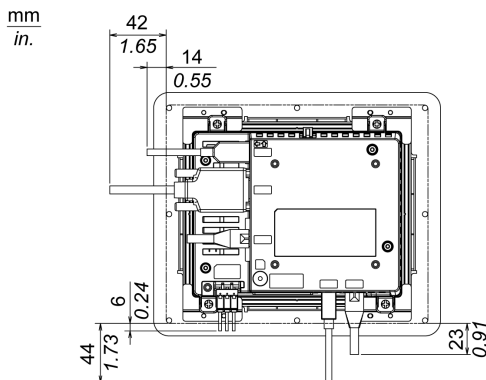

NOTE: All the above values are designed with cable bending in mind. The dimensions given here are representative values depending on the type of connection cable in use. Therefore, these values are intended for reference only.

Panel Cut Dimensions

Create a panel cut and insert the panel into the opening from the front.

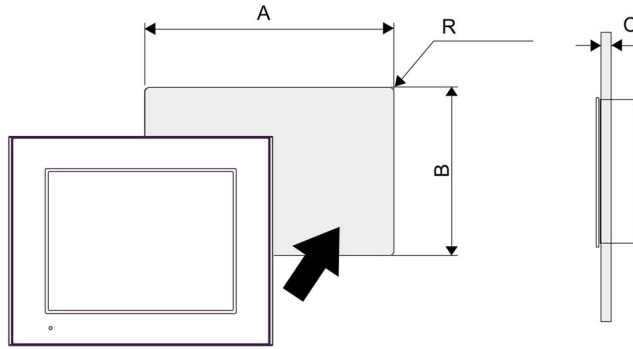

	A	B	C	R
HMIGTO2310 HMIGTO2300	156 mm (+1/-0) mm (6.14 in (+0.04, -0 in))	123.5 mm (+1, -0 mm) (4.86 in (+0.04, -0 in))	1.6...5 mm (0.06...0.2 in)	3 mm (0.12 in) maximum
HMIGTO2315	195 mm (+1/-0) mm (7.68 in (+0.04, -0 in))	162.5 mm (+1/-0) mm (6.40 in (+0.04, -0 in))		

NOTE: Before designing the panel cut, refer to Installation.

Installation Fastener Dimensions

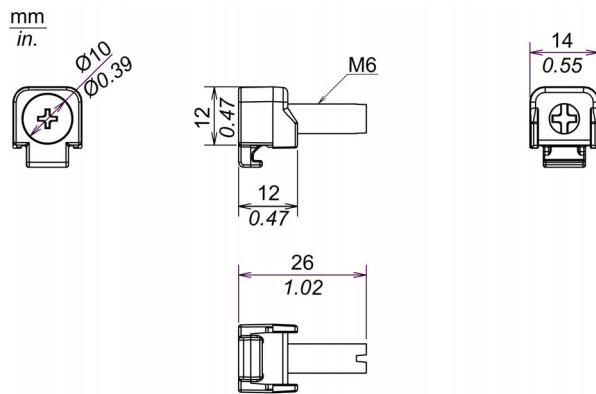

Section 4.3

HMIGTO3510/4310

What Is in This Section?

This section contains the following topics:

Topic	Page
Electrical Specifications	63
Environmental Specifications	64
Structural Specifications	65
Display Specifications	66
Memory, Clock, and Touch Panel	67
Interface Specifications	68
Specifications of Serial Interface COM1	69
Specifications of Serial Interface COM2	71
Dimensions	72

Electrical Specifications

Power Supply	Rated Input Voltage	24 Vdc	
	Input Voltage Limits	19.2...28.8 Vdc	
	Voltage Drop	5 ms or less	
	Power Consumption	12 W or less	
		When power is not supplied to external devices	8 W or less
		Backlight Dimmed (Brightness: 20%)	5.5 W or less
	In-Rush Current	30 A or less	
	Voltage Endurance	1,000 Vac, 20 mA for 1 minute (between charging and FG terminals)	
	Insulation Resistance	500 Vdc, 10 M Ω or more (between charging and FG terminals)	

Environmental Specifications

		HMIGTO4310	HMIGTO3510
Physical Environment	Surrounding Air Temperature	0...55 °C (32...131 °F)	0...50 °C (32...122 °F)
	Storage Temperature	-20...60 °C (-4...140 °F)	
	Surrounding Air and Storage Humidity	10...90% RH (Non-condensing, wet bulb temperature 39 °C (102.2 °F) or less)	
	Dust	0.1 mg/m ³ (10 ⁻⁷ oz/ft ³) or less (non-conductive levels)	
	Pollution Degree	For use in Pollution Degree 2 environment	
	Corrosive Gases	Free of corrosive gases	
	Atmospheric pressure (Operating Altitude)	800...1,114 hPa (2,000 m (6,561 ft) or lower)	
Mechanical Environment	Vibration Resistance	IEC/EN 61131-2 5...9 Hz Single amplitude 3.5 mm (0.14 in) 9...150 Hz Fixed acceleration: 9.8 m/s ² X, Y, Z directions for 10 cycles (approx. 100 min)	
	Concussion Resistance	IEC/EN 61131-2 compliant 147 m/s ² , X, Y, Z directions for three times	
Electrical Environment	Noise Immunity	Noise Voltage: 1,000 Vpp Pulse Width: 1 μs Rise Time: 1 ns	
	Electrostatic Discharge Immunity	Contact Discharge Method: 6 kV (IEC/EN 61000-4-2 Level 3)	

Air Quality Requirements

Do not operate or store the panel where chemicals evaporate, or where chemicals are present in the air:

- Corrosive chemicals: Acids, alkalines, liquids containing salt.
- Flammable chemicals: Organic solvents.

CAUTION

INOPERATIVE EQUIPMENT

Do not allow water, liquids, metal, and wiring fragments to enter the panel case.

Failure to follow these instructions can result in injury or equipment damage.

Structural Specifications

Grounding	Functional grounding: Grounding resistance of 100 Ω , 2 mm ² (AWG 14) or thicker wire, or your country's applicable standard. (Same for FG and SG terminals)
Cooling Method	Natural air circulation
Structure ^{*1}	IP65f NEMA #250 TYPE 4X/13 (on the front panel when properly installed in an enclosure)
External Dimensions	W 218 x H 173 x D 60 mm (W 8.58 x H 6.81 x D 2.36 in)
Panel Cut Dimensions	W 204.5 x H 159.5 mm (W 8.05 x H 6.28 in) ^{*2} Panel thickness area: 1.6...5 mm (0.06...0.2 in) ^{*3}
Weight	1.2 kg (2.6 lb) or less (main unit only)

NOTE: ^{*1} The front face of the HMIGTO, installed in a solid panel, has been tested using conditions equivalent to the standards shown in the specification. Even though the HMIGTO's level of resistance is equivalent to these standards, oils that should have no effect on the HMIGTO can possibly harm the panel. This can occur in areas where either vaporized oils are present, or where low viscosity cutting oils are allowed to adhere to the panel for long periods of time. If the panel's front face protection sheet peels off, these conditions can lead to the ingress of oil into the panel and separate protection measures are suggested.

Also, if non-approved oils are present, they may cause deformation or corrosion of the front panel's plastic cover. Therefore, prior to installing the HMIGTO, be sure to confirm the type of conditions that will be present in the panel's operating environment. If the installation gasket is used for a long period of time, or if the HMIGTO and its gasket are removed from the panel, the original level of protection cannot be kept. To maintain the original protection level, be sure to replace the installation gasket regularly.

^{*2} For dimensional tolerance, everything +1/-0 mm (+0.04/-0 in) and R in angle are below R3 (R0.12 in)

^{*3} Even if the installation wall thickness is within the recommended range for the "Panel Cut Dimensions", depending on wall's material, size, and installation location of the panel and other devices, the installation wall could warp. To prevent warping, the installation surface may need to be strengthened.

CAUTION

EQUIPMENT DAMAGE

Ensure that the panel is not in permanent and direct contact with oils.

Failure to follow these instructions can result in injury or equipment damage.

NOTICE

STORAGE AND OPERATION OUTSIDE OF SPECIFICATIONS

- Store this product in areas where temperatures are within the product's specifications.
- Do not restrict or block this product's ventilation slots.

Failure to follow these instructions can result in equipment damage.

NOTICE

GASKET AGING

- Inspect the gasket periodically as required by your operating environment to keep the initial IP level.
- Change the gasket at least once a year, or as soon as scratches or dirt become visible.

Failure to follow these instructions can result in equipment damage.

Display Specifications

	HMIGTO4310	HMIGTO3510
Display Type	TFT Color LCD	
Display Size	7.5"	7.0"
Resolution	640 x 480 pixels (VGA)	800 x 480 pixels (WGA)
Effective Display Area	W 153.7 x H 115. mm (W 6.05 x H 4.56 in)	W 152.4 x H 91.44 mm (W 6.0 x H 3.6 in)
Display Colors	65,536 colors	
Backlight	White LED (not user replaceable. When replacement is required, contact your local distributor.)	
Backlight Service Life	50,000 hours or more (continuous operation at 25 °C (77 °F) before backlight brightness decreases to 50%)	
Brightness Control	16 levels (Adjusted with touch panel or software)	

Memory, Clock, and Touch Panel

Memory

	HMIGTO4310	HMIGTO3510
System Memory	FLASH EPROM 128 MB (operating system, project data, and other data)	
Backup Memory	SRAM 512 KB (replaceable lithium battery for data backup)	SRAM 128 KB (replaceable lithium battery for data backup)

NOTE: When the message indicating that the battery level is low is displayed, replace the battery (*see page 134*).

Clock

Clock Accuracy*1	±65 seconds/month (deviation at room temperature and power is OFF).
------------------	---

*1 Depending on the operating temperature and age of panel, the clock can deviate from -380 to +90 sec/month. For systems where this level of precision is insufficient, the user should monitor and make adjustments when required.

Touch Panel

Touch Panel Type	Resistive Film (analog)
Touch Panel Resolution	1,024 x 1,024
Touch Panel Service Life	1 million times or more

Function Switches

HMIGTO3510: Eight switches (F1 to F8).

Interface Specifications

Serial Interface COM1

Asynchronous Transmission	RS-232C
Data Length	7 bits or 8 bits
Stop Bit	1 bit or 2 bits
Parity	None, odd or even
Data Transmission Speed	2,400...115,200 bps
Connector	D-Sub 9-pin (plug)

Serial Interface COM2

Asynchronous Transmission	RS-485
Data Length	7 bits or 8 bits
Stop Bit	1 bit or 2 bits
Parity	None, odd or even
Data Transmission Speed	2,400...115,200 bps, 187,500 bps (MPI)
Connector	Modular jack (RJ45)

USB Interface

	USB (Type A) Interface	USB (mini-B) Interface
Connector	USB 2.0 (Type A) x 1	USB 2.0 (mini-B) x 1
Power Supply Voltage	5 Vdc ±5%	-
Maximum Current Supplied	500 mA	-
Maximum Transmission Distance	5 m (16.4 ft)	

Ethernet Interface

Ethernet (LAN)	IEEE802.3i / IEEE802.3u, 10BASE-T/100BASE-TX
Connector	Modular jack (RJ45) x 1

SD Card Interface

SD card slot x 1 (maximum 32 GB SD/SDHC card)

Specifications of Serial Interface COM1

Introduction

NOTE: For information on how to connect controllers and other types of equipment, refer to the corresponding device driver manual of your screen editing software.

⚠ CAUTION

LOSS OF COMMUNICATION

- All connections to the communication ports must not put excessive stress on the ports.
- Securely attach communication cables to the panel or cabinet.
- Use only D-Sub 9-pin cables with a locking system in good condition.

Failure to follow these instructions can result in injury or equipment damage.

The serial port is not isolated. The SG (signal ground) and FG (frame ground) terminals are connected inside the panel.

⚠ ⚠ DANGER

ELECTRIC SHOCK

When using the SG terminal to connect an external device to the panel:

- Verify that a short-circuit loop is not created when you set up the system.
- Connect the #5 SG terminal to remote equipment when the host (PLC) unit is not isolated. Connect the #5 SG terminal to a known reliable ground connection to reduce the risk of damaging the circuit.

Failure to follow these instructions will result in death or serious injury.

Serial Interface COM1

HMIGTO3510 / HMIGTO4310: D-Sub 9-pin plug connector via a RS-232C cable.

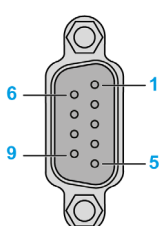
Pin Connection	Pin No.	RS-232C		
		Signal Name	Direction	Meaning
	1	CD	Input	Carrier Detect
	2	RD(RXD)	Input	Receive Data
	3	SD(TXD)	Output	Send Data
	4	ER(DTR)	Output	Data Terminal Ready
	5	SG	-	Signal Ground
	6	DR(DSR)	Input	Data Set Ready
	7	RS(RTS)	Output	Request to Send
	8	CS(CTS)	Input	Send possible
	9	CI(RI)/VCC	Input-	Called Status Display +5 V±5% Output 0.25 A*1
	Shell	FG	-	Frame Ground (Common with SG)

NOTE: *1 You can switch pin number 9 between RI and VCC via software.

NOTICE

EQUIPMENT DAMAGE

Use only the rated current.

Failure to follow these instructions can result in equipment damage.

 **CAUTION**

LOSS OF COMMUNICATION

- All connections to the communication ports must not put excessive stress on the ports.
- Securely attach communication cables to the panel wall or cabinet.
- Use only D-Sub 9 pin cables with a locking tab in good condition.

Failure to follow these instructions can result in injury or equipment damage.

Specifications of Serial Interface COM2

Introduction

NOTE: For information on how to connect controllers and other types of equipment, refer to the corresponding device driver manual of your screen editing software.

The serial port is not isolated. The SG (signal ground) and FG (frame ground) terminals are connected inside the panel.

DANGER

ELECTRIC SHOCK

When using the SG terminal to connect an external device to the panel:

- Verify that a short-circuit loop is not created when you set up the system.
- Connect the #8 SG terminal to remote equipment when the host (PLC) unit is not isolated. Connect the #8 SG terminal to a known reliable ground connection to reduce the risk of damaging the circuit.

Failure to follow these instructions will result in death or serious injury.

Serial Interface COM2

HMIGTO3510 / HMIGTO4310: RJ45 connector via an RS-485 cable.

NOTE: When setting up RS-485 communication, the cable diagram for some equipment may require polarization on the terminal side. This terminal does not require any special setting as it handles polarization automatically.

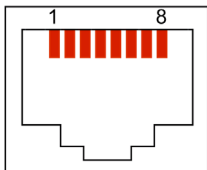
Pin Connection	Pin No.	RS-485		
		Signal Name	Direction	Meaning
	1	NC	-	-
	2	NC	-	-
	3	NC	-	-
	4	Line A	Input/Output	Transfer Data (RS-485)
	5	Line B	Input/Output	Transfer Data (RS-485)
	6	RS(RTS)	Output	Request To Send
	7	NC	-	-
	8	SG	-	Signal Ground

CAUTION

LOSS OF COMMUNICATION

- All connections to the communication ports must not put excessive stress on the ports.
- Securely attach communication cables to the panel wall or cabinet.
- Use only RJ45 with a locking tab in good condition.

Failure to follow these instructions can result in injury or equipment damage.

Dimensions

External Dimensions: HMIGTO3510

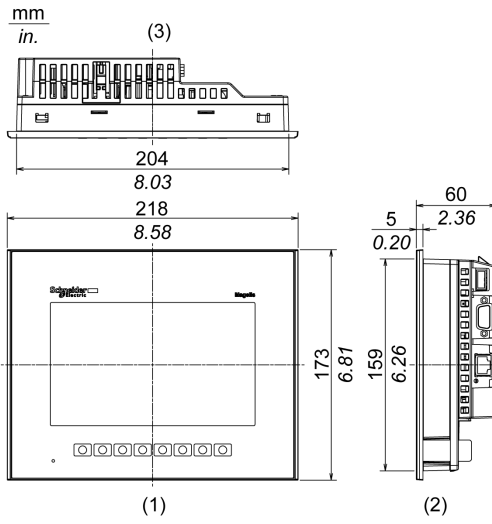

- 1 Front
- 2 Right side
- 3 Top

External Dimensions: HMIGTO4310

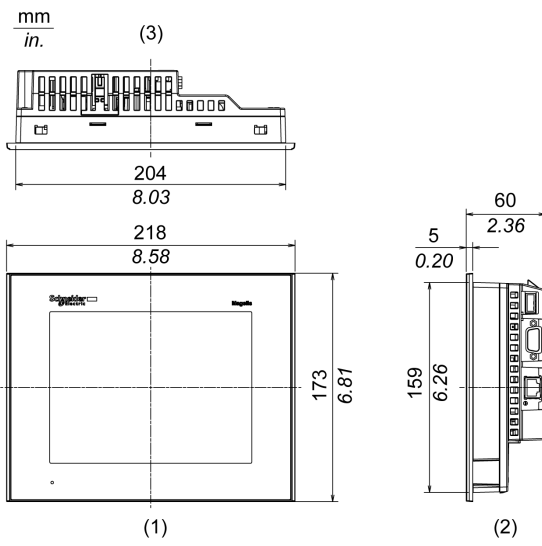

- 1 Front
- 2 Right side
- 3 Top

Installation with Installation Fasteners: HMIGTO3510

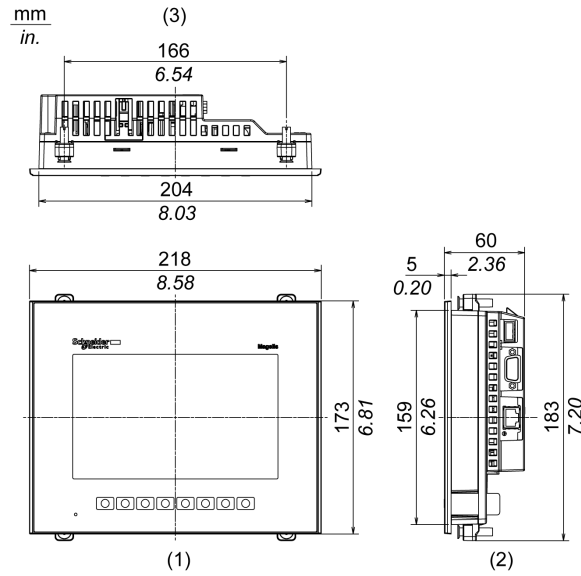

- 1 Front
- 2 Right side
- 3 Top

Installation with Installation Fasteners: HMIGTO4310

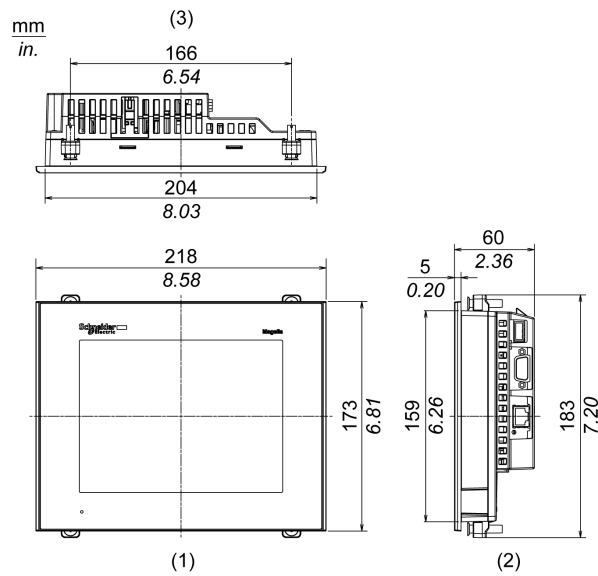

- 1 Front
- 2 Right side
- 3 Top

Dimensions with Cables: HMIGTO3510

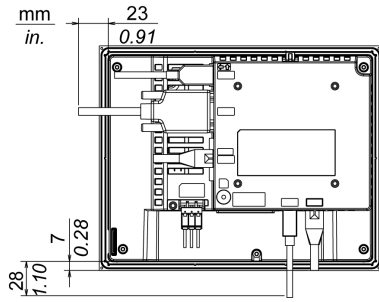

NOTE: All the above values are designed with cable bending in mind. The dimensions given here are representative values depending on the type of connection cable in use. Therefore, these values are intended for reference only.

Dimensions with Cables: HMIGTO4310

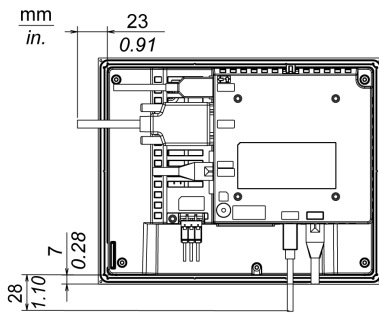

NOTE: All the above values are designed with cable bending in mind. The dimensions given here are representative values depending on the type of connection cable in use. Therefore, these values are intended for reference only.

Panel Cut Dimensions

Create a panel cut and insert the panel into the opening from the front.

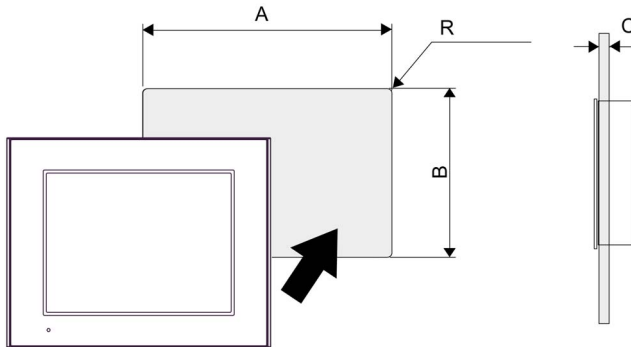

A	B	C	R
204.5 mm (+1, -0 mm) (8.05 in (+0.04, -0 in))	159.5 mm (+1, -0 mm) (6.28 in (+0.04, -0 in))	1.6...5 mm (0.06...0.2 in)	3 mm (0.12 in) maximum

NOTE: Before designing the panel cut, refer to Installation.

Installation Fastener Dimensions

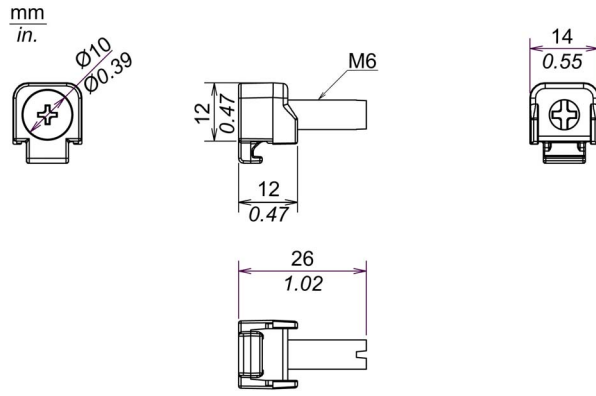

Section 4.4

HMIGTO5310/5315

What Is in This Section?

This section contains the following topics:

Topic	Page
Electrical Specifications	77
Environmental Specifications	78
Structural Specifications	79
Display Specifications	81
Memory, Clock, and Touch Panel	82
Interface Specifications	83
Specifications of Serial Interface COM1	84
Specifications of Serial Interface COM2	86
Dimensions	87

Electrical Specifications

Power Supply	Rated Input Voltage	24 Vdc	
	Input Voltage Limits	19.2...28.8 Vdc	
	Voltage Drop	10 ms or less	
	Power Consumption	17 W or less	
		When power is not supplied to external devices	12 W or less
		Backlight Dimmed (Brightness: 20%)	8 W or less
	In-Rush Current	30 A or less	
	Voltage Endurance	1500 Vac, 20 mA for 1 min (between charging and FG terminals)	
	Insulation Resistance	500 Vdc, 10 MΩ or more (between charging and FG terminals)	

Environmental Specifications

Physical Environment	Surrounding Air Temperature	0...55 °C (32...131 °F)
	Storage Temperature	-20...60 °C (-4...140 °F)
	Surrounding Air and Storage Humidity	10...90% RH (Non-condensing, wet bulb temperature 39 °C (102.2 °F) or less)
	Dust	0.1 mg/m ³ (10 ⁻⁷ oz/ft ³) or less (non-conductive levels)
	Pollution Degree	For use in Pollution Degree 2 environment
	Corrosive Gases	Free of corrosive gases
	Atmospheric Pressure (Operating Altitude)	800...1,114 hPa (2,000 m (6,561 ft) or lower)
Mechanical Environment	Vibration Resistance	IEC/EN 61131-2 compliant 5...9 Hz Single amplitude 3.5 mm (0.14 in) 9...150 Hz Fixed acceleration: 9.8 m/s ² X, Y, Z directions for 10 cycles (approx. 100 min)
	Concussion Resistance	IEC/EN 61131-2 compliant 147 m/s ² , X, Y, Z directions for three times
Electrical Environment	Noise Immunity	Noise Voltage: 1,000 Vpp Pulse Width: 1 µs Rise Time: 1 ns
	Electrostatic Discharge Immunity	Contact Discharge Method: 6 kV (IEC/EN 61000-4-2 Level 3)

Air Quality Requirements

Do not operate or store the panel where chemicals evaporate, or where chemicals are present in the air:

- Corrosive chemicals: Acids, alkalines, liquids containing salt.
- Flammable chemicals: Organic solvents.

CAUTION

INOPERATIVE EQUIPMENT

Do not allow water, liquids, metal, and wiring fragments to enter the panel case.

Failure to follow these instructions can result in injury or equipment damage.

Structural Specifications

	HMIGTO5310	HMIGTO5315
Grounding	Functional grounding: Grounding resistance of 100 Ω , 2 mm ² (AWG 14) or thicker wire, or your country's applicable standard. (Same for FG and SG terminals)	
Cooling Method	Natural air circulation	
Structure ^{*1}	IP65f NEMA #250 TYPE 4X/13 (on the front panel when properly installed in an enclosure)	IP66k NEMA #250 TYPE 4X/13 (on the front panel when properly installed in an enclosure) ^{*2}
External Dimensions	W 272.5 x H 214.5 x D 57 mm (W 10.73 x H 8.44 x D 2.24 in)	W 316.5 x H 258.5 x D 57 mm (W 12.44 x H 10.18 x D 2.24 in)
Panel Cut Dimensions	W 259 x H 201 mm (W 10.2 x H 7.91 in) ^{*3} Panel thickness area: 1.6...5 mm (0.06...0.2 in) ^{*4}	W 298 x H 240 mm (W 11.73 x H 9.45 in) ^{*3} Panel thickness area: 1.6...5 mm (0.06...0.2 in) ^{*4}
Weight	2.0 kg (4.4 lb) or less (main unit only)	2.5 kg (5.5 lb) or less (main unit only)

NOTE: ^{*1} The front face of the HMIGTO, installed in a solid panel, has been tested using conditions equivalent to the standards shown in the specification. Even though the HMIGTO's level of resistance is equivalent to these standards, oils that should have no effect on the HMIGTO can possibly harm the panel. This can occur in areas where either vaporized oils are present, or where low viscosity cutting oils are allowed to adhere to the panel for long periods of time. If the panel's front face protection sheet peels off, these conditions can lead to the ingress of oil into the panel and separate protection measures are suggested.

Also, if non-approved oils are present, they may cause deformation or corrosion of the front panel's plastic cover. Therefore, prior to installing the HMIGTO, be sure to confirm the type of conditions that will be present in the panel's operating environment. If the installation gasket is used for a long period of time, or if the HMIGTO and its gasket are removed from the panel, the original level of protection cannot be kept. To maintain the original protection level, be sure to replace the installation gasket regularly.

^{*2} When installing the HMIGTO in a panel, you may not be able to mount the HMIGTO flush with the panel. This occurs due to the thickness of the gasket. The difference in level between the HMIGTO and panel depends on how much the gasket is compressed.

There is a conformal coating on circuit boards for HMIGTO5315.

NOTICE

EQUIPMENT DAMAGE

For food and beverage and pharmaceutical industries, when the HMIGTO is not flush with panel, use silicon to form a seal to prevent water, chemicals, or food from lodging into place.

Failure to follow these instructions can result in equipment damage.

^{*3} For dimensional tolerance, everything +1/-0 mm (+0.04/-0 in), and R in angle are below R3 (R0.12 in)

^{*4} Even if the installation wall thickness is within the recommended range for the "Panel Cut Dimensions", depending on wall's material, size, and installation location of the panel and other devices, the installation wall could warp. To prevent warping, the installation surface may need to be strengthened.

CAUTION

EQUIPMENT DAMAGE

Ensure that the panel is not in permanent and direct contact with oils.

Failure to follow these instructions can result in injury or equipment damage.

NOTICE

STORAGE AND OPERATION OUTSIDE OF SPECIFICATIONS

- Store this product in areas where temperatures are within the product's specifications.
- Do not restrict or block this product's ventilation slots.

Failure to follow these instructions can result in equipment damage.

NOTICE

GASKET AGING

- Inspect the gasket periodically as required by your operating environment to keep the initial IP level.
- Change the gasket at least once a year, or as soon as scratches or dirt become visible.

Failure to follow these instructions can result in equipment damage.

Display Specifications

Display Type	TFT Color LCD
Display Size	10.4"
Resolution	640 x 480 pixels (VGA)
Effective Display Area	W 211.2 x H 158.4 mm (8.31 x 6.24 in)
Display Colors	65,536 colors
Backlight	White LED (Not user replaceable. When replacement is required, contract your local distributor.)
Backlight Service Life	50,000 hours or more (continuous operation at 25 °C (77 °F) before backlight brightness dimmed to 50%)
Brightness Control	16 levels (Adjusted with the touch panel or software)

Memory, Clock, and Touch Panel

Memory

System Memory	Flash EPROM 128 MB (operating system, project data, and other data)
Backup Memory	SRAM 512 KB (replaceable lithium battery for data backup)

NOTE: When the message indicating that the battery level is low is displayed, replace the battery (*see page 134*).

Clock

Clock Accuracy ^{*1}	±65 seconds/month (deviation at room temperature and power is OFF).
------------------------------	---

*1 Depending on the operating temperature and age of panel, the clock can deviate from -380 to +90 sec/month. For systems where this level of precision is insufficient, the user should monitor and make adjustments when required.

Touch Panel

Touch Panel Type	Resistive Film (analog)
Touch Panel Resolution	1,024 x 1,024
Service Life	1 million times or more

Interface Specifications

Serial Interface COM1

Asynchronous Transmission	RS-232C
Data Length	7 bits or 8 bits
Stop Bit	1 bit or 2 bits
Parity	None, odd or even
Data Transmission Speed	2,400...115,200 bps
Connector	D-Sub 9-pin (plug)

Serial Interface COM2

Asynchronous Transmission	RS-485
Data Length	7 bits or 8 bits
Stop Bit	1 bit or 2 bits
Parity	None, odd or even
Data Transmission Speed	2,400...115,200 bps, 187,500 bps (MPI)
Connector	Modular jack (RJ45)

USB Interface

	USB (Type A) Interface	USB (mini-B) Interface
Connector	USB 2.0 (Type A) x 1	USB 2.0 (mini-B) x 1
Power Supply Voltage	5 Vdc \pm 5%	-
Maximum Current Supplied	500 mA	-
Maximum Transmission Distance	5 m (16.4 ft)	

Ethernet Interface

Ethernet (LAN)	IEEE802.3i / IEEE802.3u, 10BASE-T/100BASE-TX
Connector	Modular jack (RJ45) x 1

SD Card Interface

SD card slot x 1 (maximum 32 GB SD/SDHC card)

Specifications of Serial Interface COM1

Introduction

NOTE: For information on how to connect controllers and other types of equipment, refer to the corresponding device driver manual of your screen editing software.

⚠ CAUTION
<p>LOSS OF COMMUNICATION</p> <ul style="list-style-type: none"> All connections to the communication ports must not put excessive stress on the ports. Securely attach communication cables to the panel or cabinet. Use only D-Sub 9-pin cables with a locking system in good condition. <p>Failure to follow these instructions can result in injury or equipment damage.</p>

The serial port is not isolated. The SG (signal ground) and FG (frame ground) terminals are connected inside the panel.

⚠ ⚠ DANGER
<p>ELECTRIC SHOCK</p> <p>When using the SG terminal to connect an external device to the panel:</p> <ul style="list-style-type: none"> Verify that a short-circuit loop is not created when you set up the system. Connect the #5 SG terminal to remote equipment when the host (PLC) unit is not isolated. Connect the #5 SG terminal to a known reliable ground connection to reduce the risk of damaging the circuit. <p>Failure to follow these instructions will result in death or serious injury.</p>

Serial Interface COM1

HMIGTO5310 / HMIGTO5315: D-Sub 9-pin plug connector via a RS-232C cable.

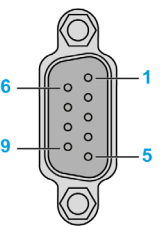
Pin Connection	Pin No.	RS-232C		
		Signal Name	Direction	Meaning
	1	CD	Input	Carrier Detect
	2	RD(RXD)	Input	Receive Data
	3	SD(TXD)	Output	Send Data
	4	ER(DTR)	Output	Data Terminal Ready
	5	SG	-	Signal Ground
	6	DR(DSR)	Input	Data Set Ready
	7	RS(RTS)	Output	Request to Send
	8	CS(CTS)	Input	Send possible
	9	CI(RI)/VCC	Input-	Called Status Display +5 V±5% Output 0.25 A ^{*1}
	Shell	FG	-	Frame Ground (Common with SG)

NOTE: ^{*1} You can switch pin number 9 between RI and VCC via software.

NOTICE
<p>EQUIPMENT DAMAGE</p> <p>Use only the rated current.</p> <p>Failure to follow these instructions can result in equipment damage.</p>

⚠ CAUTION**LOSS OF COMMUNICATION**

- All connections to the communication ports must not put excessive stress on the ports.
- Securely attach communication cables to the panel wall or cabinet.
- Use only D-Sub 9 pin cables with a locking tab in good condition.

Failure to follow these instructions can result in injury or equipment damage.

Specifications of Serial Interface COM2

Introduction

NOTE: For information on how to connect controllers and other types of equipment, refer to the corresponding device driver manual of your screen editing software.

The serial port is not isolated. The SG (signal ground) and FG (frame ground) terminals are connected inside the panel.

⚡ ⚠ DANGER

ELECTRIC SHOCK

When using the SG terminal to connect an external device to the panel:

- Verify that a short-circuit loop is not created when you set up the system.
- Connect the #8 SG terminal to remote equipment when the host (PLC) unit is not isolated. Connect the #8 SG terminal to a known reliable ground connection to reduce the risk of damaging the circuit.

Failure to follow these instructions will result in death or serious injury.

Serial Interface COM2

HMIGTO5310 / HMIGTO5315: RJ45 connector via an RS-485 cable.

NOTE: When setting up RS-485 communication, the cable diagram for some equipment may require polarization on the terminal side. This terminal does not require any special setting as it handles polarization automatically.

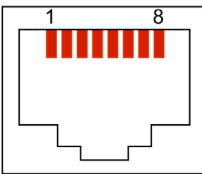
Pin Connection	Pin No.	RS-485		
		Signal Name	Direction	Meaning
	1	NC	-	-
	2	NC	-	-
	3	NC	-	-
	4	Line A	Input/Output	Transfer Data (RS-485)
	5	Line B	Input/Output	Transfer Data (RS-485)
	6	RS(RTS)	Output	Request To Send
	7	NC	-	-
	8	SG	-	Signal Ground

⚠ CAUTION

LOSS OF COMMUNICATION

- All connections to the communication ports must not put excessive stress on the ports.
- Securely attach communication cables to the panel wall or cabinet.
- Use only RJ45 with a locking tab in good condition.

Failure to follow these instructions can result in injury or equipment damage.

Dimensions

External Dimensions: HMIGTO5310

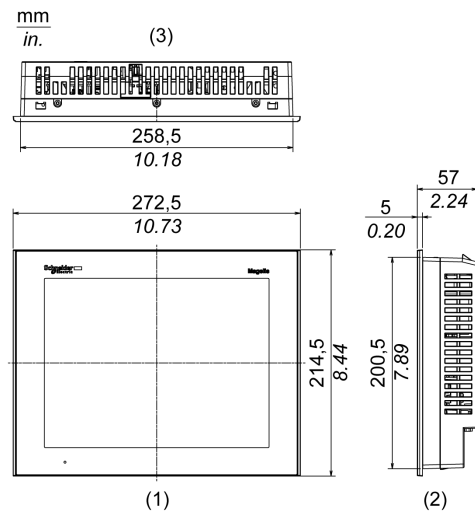

- 1 Front
- 2 Right side
- 3 Top

External Dimensions: HMIGTO5315

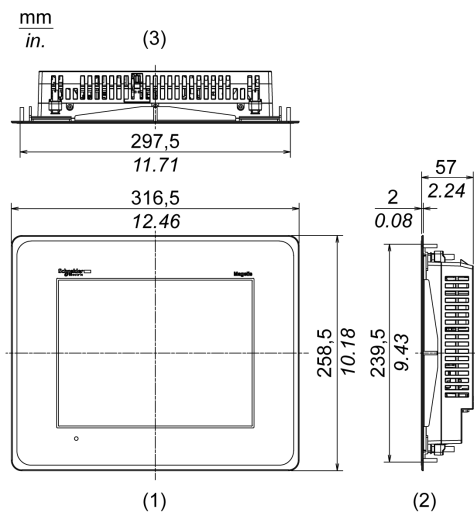

- 1 Front
- 2 Right side
- 3 Top

Installation with Installation Fasteners: HMIGTO5310

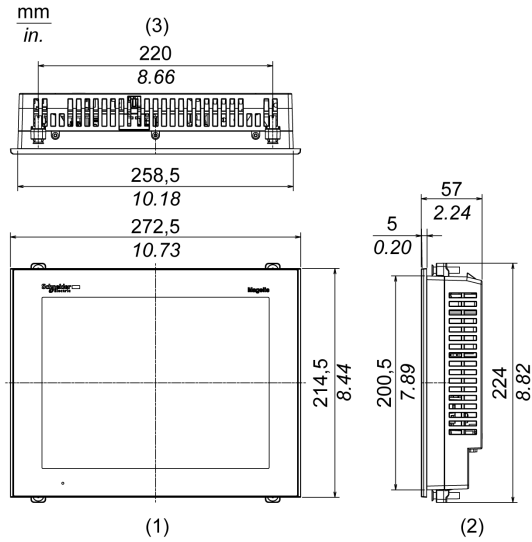

- 1 Front
- 2 Right side
- 3 Top

Installation with Installation Fasteners: HMIGTO5315

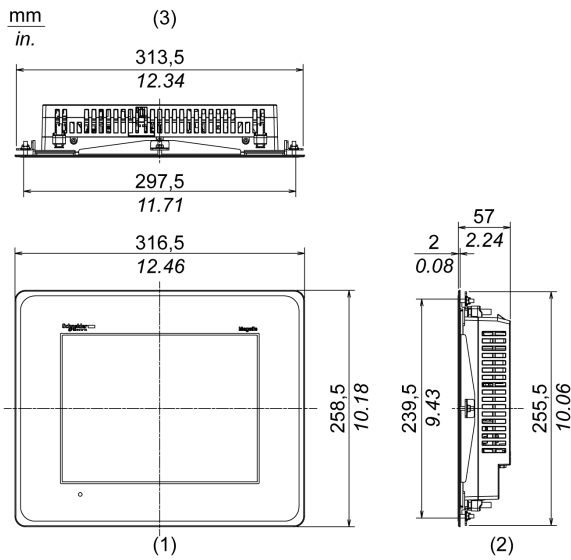

- 1 Front
- 2 Right side
- 3 Top

Dimensions with Cables: HMIGTO5310

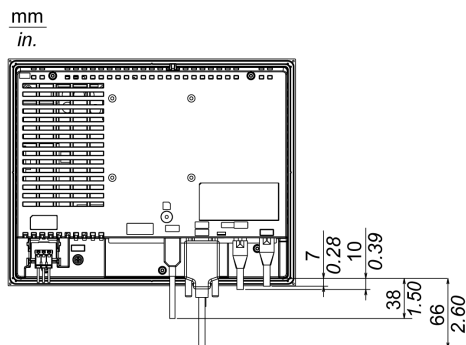

NOTE: All the above values are designed with cable bending in mind. The dimensions given here are representative values depending on the type of connection cable in use. Therefore, these values are intended for reference only.

Dimensions with Cables: HMIGTO5315

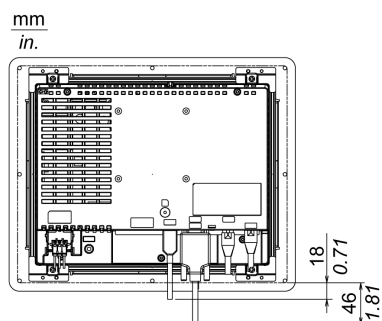

NOTE: All the above values are designed with cable bending in mind. The dimensions given here are representative values depending on the type of connection cable in use. Therefore, these values are intended for reference only.

Panel Cut Dimensions

Create a panel cut and insert the panel into the opening from the front.

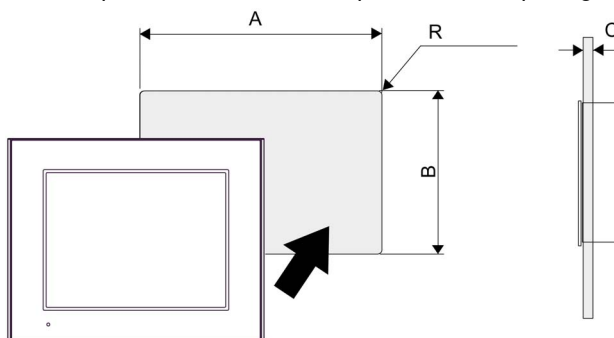

	A	B	C	R
HMIGTO5310	259 mm (+1, -0 mm) (10.2 in (+0.04, -0 in))	201 mm (+1, -0 mm) (7.91 in (+0.04, -0 in))	1.6...5 mm (0.06...0.2 in)	3 mm (0.12 in) maximum
HMIGTO5315	298 mm (+1, -0 mm) (11.73 in (+0.04, -0 in))	240 mm (+1, -0 mm) (9.45 in (+0.04, -0 in))		

NOTE: Before designing the panel cut, refer to Installation.

Installation Fastener Dimensions

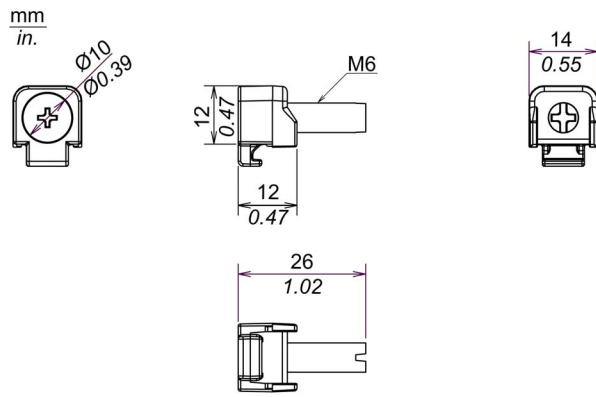

Section 4.5

HMIGTO6310/6315

What Is in This Section?

This section contains the following topics:

Topic	Page
Electrical Specifications	92
Environmental Specifications	93
Structural Specifications	94
Display Specifications	96
Memory, Clock, and Touch Panel	97
Interface Specifications	98
Specifications of Serial Interface COM1	99
Specifications of Serial Interface COM2	101
Dimensions	102

Electrical Specifications

Power Supply	Rated Input Voltage	24 Vdc	
	Input Voltage Limits	19.2...28.8 Vdc	
	Voltage Drop	10 ms or less	
	Power Consumption	17 W or less	
		When power is not supplied to external devices	12 W or less
		Backlight Dimmed (Brightness: 20%)	8 W or less
	In-Rush Current	30 A or less	
Voltage Endurance		1,500 Vac, 20 mA for 1 minute (between charging and FG terminals)	
Insulation Resistance		500 Vdc, 10 MΩ or more (between charging and FG terminals)	

Environmental Specifications

Physical Environment	Surrounding Air Temperature	0...55 °C (32...131 °F)
	Storage Temperature	-20...60 °C (-4...140 °F)
	Surrounding Air and Storage Humidity	10...90% RH (Non-condensing, wet bulb temperature 39 °C (102.2 °F) or less)
	Dust	0.1 mg/m ³ (10 ⁻⁷ oz/ft ³) or less (non-conductive levels)
	Pollution Degree	For use in Pollution Degree 2 environment
	Corrosive gases	Free of corrosive gases
Mechanical Environment	Atmospheric Pressure (Operating Altitude)	800...1,114 hPa (2,000 m (6,561 ft) or lower)
	Vibration Resistance	IEC/EN 61131-2 compliant 5...9 Hz Single amplitude 3.5 mm (0.14 in) 9...150 Hz Fixed acceleration: 9.8 m/s ² X, Y, Z directions for 10 cycles (approx. 100 minute)
Electrical Environment	Concussion Resistance	IEC/EN 61131-2 compliant 147 m/s ² , X, Y, Z directions for three times
	Noise immunity	Noise Voltage: 1,000 Vpp Pulse Width: 1 µs Rise Time: 1 ns
	Electrostatic Discharge Immunity	Contact Discharge Method: 6 kV (IEC/EN 61000-4-2 Level 3)

Air Quality Requirements

Do not operate or store the panel where chemicals evaporate, or where chemicals are present in the air:

- Corrosive chemicals: Acids, alkalines, liquids containing salt.
- Flammable chemicals: Organic solvents.

CAUTION

INOPERATIVE EQUIPMENT

Do not allow water, liquids, metal, and wiring fragments to enter the panel case.

Failure to follow these instructions can result in injury or equipment damage.

Structural Specifications

	HMIGTO6310	HMIGTO6315
Grounding	Functional grounding: Grounding resistance of 100 Ω, 2 mm ² (AWG 14) or thicker wire, or your country's applicable standard. (Same for FG and SG terminals)	
Cooling Method	Natural air circulation	
Structure ^{*1}	IP65f NEMA #250 TYPE 4X/13 (on the front panel when properly installed in an enclosure)	IP66k NEMA #250 TYPE 4X/13 (on the front panel when properly installed in an enclosure) ^{*2}
External Dimensions	W 315 x H 241 x D 56 mm (W 12.4 x H 9.49 x D 2.2 in)	W 359 x H 285 x D 56 mm (W 14.13 x H 11.22 x D 2.2 in)
Panel Cut Dimensions	W 301.5 x H 227.5 mm (W 11.87 x H 8.96 in) ^{*3} Panel thickness area: 1.6...5 mm (0.06...0.2 in) ^{*4}	W 340.5 x H 266.5 mm (W 13.41 x H 10.49 in) ^{*3} Panel thickness area: 1.6...5 mm (0.06...0.2 in) ^{*4}
Weight	2.5 kg (5.5 lb) or less (main unit only)	3 kg (6.6 lb) or less (main unit only)

NOTE: ^{*1} The front face of the HMIGTO, installed in a solid panel, has been tested using conditions equivalent to the standards shown in the specification. Even though the HMIGTO's level of resistance is equivalent to these standards, oils that should have no effect on the HMIGTO can possibly harm the panel. This can occur in areas where either vaporized oils are present, or where low viscosity cutting oils are allowed to adhere to the panel for long periods of time. If the panel's front face protection sheet peels off, these conditions can lead to the ingress of oil into the panel and separate protection measures are suggested.

Also, if non-approved oils are present, they may cause deformation or corrosion of the front panel's plastic cover. Therefore, prior to installing the HMIGTO, be sure to confirm the type of conditions that will be present in the panel's operating environment. If the installation gasket is used for a long period of time, or if the HMIGTO and its gasket are removed from the panel, the original level of protection cannot be kept. To maintain the original protection level, be sure to replace the installation gasket regularly.

^{*2} When installing the HMIGTO in a panel, you may not be able to mount the HMIGTO flush with the panel. This occurs due to the thickness of the gasket. The difference in level between the HMIGTO and panel depends on how much the gasket is compressed.

There is a conformal coating on circuit boards for HMIGTO6315.

<i>NOTICE</i>
EQUIPMENT DAMAGE
For food and beverage and pharmaceutical industries, when the HMIGTO is not flush with panel, use silicon to form a seal to prevent water, chemicals, or food from lodging into place.
Failure to follow these instructions can result in equipment damage.

^{*3} For dimensional tolerance, everything +1/-0 mm (+0.04/-0 in), and R in angle are below R3 (R0.12 in)

^{*4} Even if the installation wall thickness is within the recommended range for the "Panel Cut Dimensions", depending on wall's material, size, and installation location of the panel and other devices, the installation wall could warp. To prevent warping, the installation surface may need to be strengthened.

 CAUTION
EQUIPMENT DAMAGE
Ensure that the panel is not in permanent and direct contact with oils.
Failure to follow these instructions can result in injury or equipment damage.

NOTICE**STORAGE AND OPERATION OUTSIDE OF SPECIFICATIONS**

- Store this product in areas where temperatures are within the product's specifications.
- Do not restrict or block this product's ventilation slots.

Failure to follow these instructions can result in equipment damage.

NOTICE**GASKET AGING**

- Inspect the gasket periodically as required by your operating environment to keep the initial IP level.
- Change the gasket at least once a year, or as soon as scratches or dirt become visible.

Failure to follow these instructions can result in equipment damage.

Display Specifications

Display Type	TFT Color LCD
Display Size	12.1"
Resolution	800 x 600 pixels (SVGA)
Effective Display Area	W 246.0 x H 184.5 mm (9.69 x 7.26 in)
Display Colors	65,536 colors
Backlight	White LED (Not user replaceable. When replacement is required, contact your local distributor.)
Backlight Service Life	50,000 hours (continuous operation at 25 °C (77 °F) before backlight brightness decreases to 50%)
Brightness Control	16 levels (Adjusted with touch panel or software)

Memory, Clock, and Touch Panel

Memory

System Memory	Flash EPROM 128 MB (operating system, project data, and other data)
Backup Memory	SRAM 512 KB (replaceable lithium battery for data backup)

NOTE: When the message indicating that the battery level is low is displayed, replace the battery (*see page 134*).

Clock

Clock Accuracy*1	±65 seconds/month (deviation at room temperature and power is OFF).
------------------	---

*1 Depending on the operating temperature and age of the panel, the clock can deviate from -380 to +90 sec/month. For systems where this level of precision is insufficient, the user should monitor and make adjustments when required.

Touch Panel

Touch Panel Type	Resistive Film (analog)
Touch Panel Resolution	1,024 x 1,024
Touch Panel Service Life	1 million times or more

Interface Specifications

Serial Interface COM1

Asynchronous Transmission	RS-232C
Data Length	7 bits or 8 bits
Stop Bit	1 bit or 2 bits
Parity	None, odd or even
Data Transmission Speed	2,400...115,200 bps
Connector	D-Sub 9-pin (plug)

Serial Interface COM2

Asynchronous Transmission	RS-485
Data Length	7 bits or 8 bits
Stop Bit	1 bit or 2 bits
Parity	None, odd or even
Data Transmission Speed	2,400...115,200 bps, 187,500 bps (MPI)
Connector	Modular jack (RJ45)

USB Interface

	USB (Type A) Interface	USB (mini-B) Interface
Connector	USB 2.0 (Type A) x 1	USB 2.0 (mini-B) x 1
Power Supply Voltage	5 Vdc ±5%	-
Maximum Current Supplied	500 mA	-
Maximum Transmission Distance	5 m (16.4 ft)	

Ethernet Interface

Ethernet (LAN)	IEEE802.3i / IEEE802.3u, 10BASE-T/100BASE-TX
Connector	Modular jack (RJ45) x 1

SD Card Interface

SD card slot x 1 (maximum 32 GB SD/SDHC card)

Specifications of Serial Interface COM1

Introduction

NOTE: For information on how to connect controllers and other types of equipment, refer to the corresponding device driver manual of your screen editing software.

⚠ CAUTION

LOSS OF COMMUNICATION

- All connections to the communication ports must not put excessive stress on the ports.
- Securely attach communication cables to the panel or cabinet.
- Use only D-Sub 9-pin cables with a locking system in good condition.

Failure to follow these instructions can result in injury or equipment damage.

The serial port is not isolated. The SG (signal ground) and FG (frame ground) terminals are connected inside the panel.

⚠ ⚠ DANGER

ELECTRIC SHOCK

When using the SG terminal to connect an external device to the panel:

- Verify that a short-circuit loop is not created when you set up the system.
- Connect the #5 SG terminal to remote equipment when the host (PLC) unit is not isolated. Connect the #5 SG terminal to a known reliable ground connection to reduce the risk of damaging the circuit.

Failure to follow these instructions will result in death or serious injury.

Serial Interface COM1

HMIGTO6310 / HMIGTO6315: D-Sub 9-pin plug connector via a RS-232C cable.

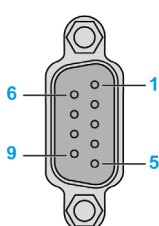
Pin Connection	Pin No.	RS-232C		
		Signal Name	Direction	Meaning
	1	CD	Input	Carrier Detect
	2	RD(RXD)	Input	Receive Data
	3	SD(TXD)	Output	Send Data
	4	ER(DTR)	Output	Data Terminal Ready
	5	SG	-	Signal Ground
	6	DR(DSR)	Input	Data Set Ready
	7	RS(RTS)	Output	Request to Send
	8	CS(CTS)	Input	Send possible
	9	CI(RI)/VCC	Input-	Called Status Display +5 V±5% Output 0.25 A*1
	Shell	FG	-	Frame Ground (Common with SG)

NOTE: *1 You can switch pin number 9 between RI and VCC via software.

NOTICE

EQUIPMENT DAMAGE

Use only the rated current.

Failure to follow these instructions can result in equipment damage.

 **CAUTION**

LOSS OF COMMUNICATION

- All connections to the communication ports must not put excessive stress on the ports.
- Securely attach communication cables to the panel wall or cabinet.
- Use only D-Sub 9 pin cables with a locking tab in good condition.

Failure to follow these instructions can result in injury or equipment damage.

Specifications of Serial Interface COM2

Introduction

NOTE: For information on how to connect controllers and other types of equipment, refer to the corresponding device driver manual of your screen editing software.

The serial port is not isolated. The SG (signal ground) and FG (frame ground) terminals are connected inside the panel.

DANGER

ELECTRIC SHOCK

When using the SG terminal to connect an external device to the panel:

- Verify that a short-circuit loop is not created when you set up the system.
- Connect the #8 SG terminal to remote equipment when the host (PLC) unit is not isolated. Connect the #8 SG terminal to a known reliable ground connection to reduce the risk of damaging the circuit.

Failure to follow these instructions will result in death or serious injury.

Serial Interface COM2

HMIGTO6310 / HMIGTO6315: RJ45 connector via a RS-485 cable.

NOTE: When setting up RS-485 communication, the cable diagram for some equipment may require polarization on the terminal side. This terminal does not require any special setting as it handles polarization automatically.

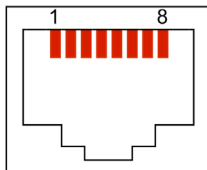
Pin Connection	Pin No.	RS-485		
		Signal Name	Direction	Meaning
	1	NC	-	-
	2	NC	-	-
	3	NC	-	-
	4	Line A	Input/Output	Transfer Data (RS-485)
	5	Line B	Input/Output	Transfer Data (RS-485)
	6	RS(RTS)	Output	Request To Send
	7	NC	-	-
	8	SG	-	Signal Ground

CAUTION

LOSS OF COMMUNICATION

- All connections to the communication ports must not put excessive stress on the ports.
- Securely attach communication cables to the panel wall or cabinet.
- Use only RJ45 with a locking tab in good condition.

Failure to follow these instructions can result in injury or equipment damage.

Dimensions

External Dimensions: HMIGTO6310

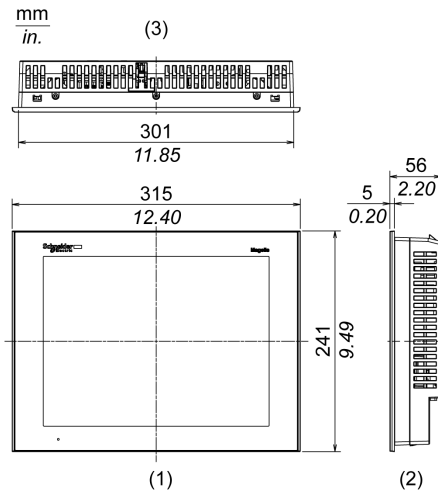

- 1 Front
- 2 Right side
- 3 Top

External Dimensions: HMIGTO6315

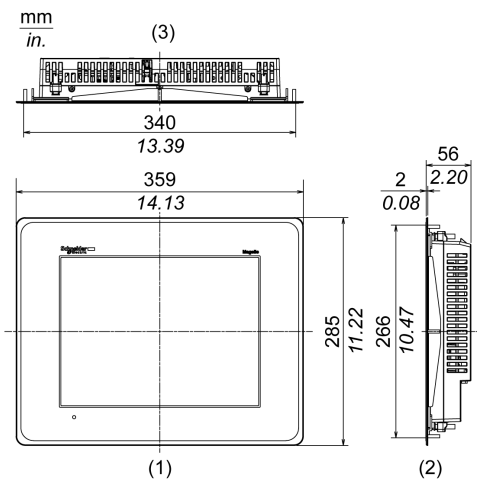

- 1 Front
- 2 Right side
- 3 Top

Installation with Installation Fasteners: HMIGTO6310

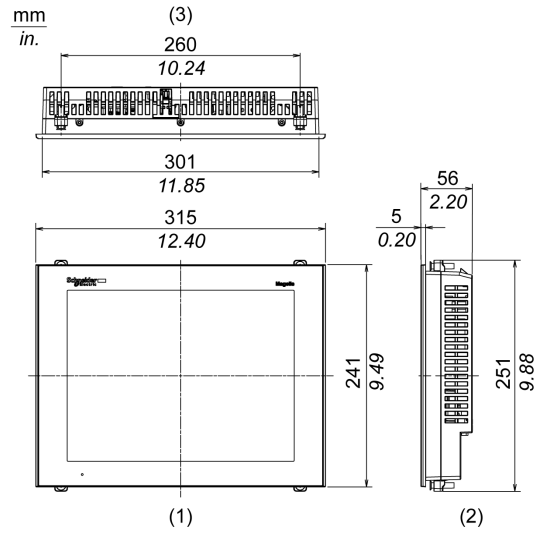

- 1 Front
- 2 Right side
- 3 Top

Installation with Installation Fasteners: HMIGTO6315

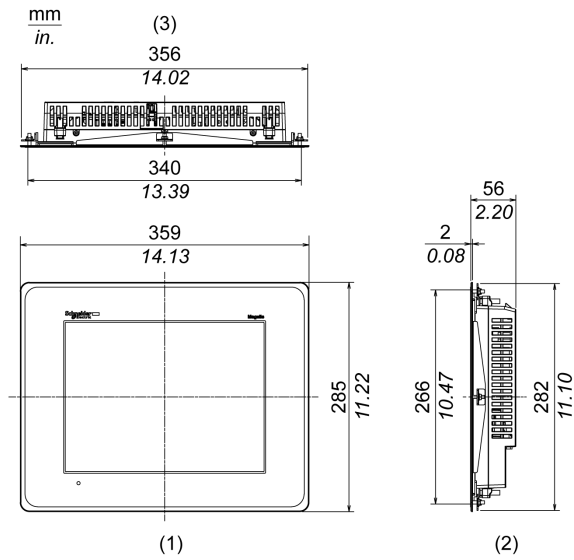

- 1 Front
- 2 Right side
- 3 Top

Dimensions with Cables: HMIGTO6310

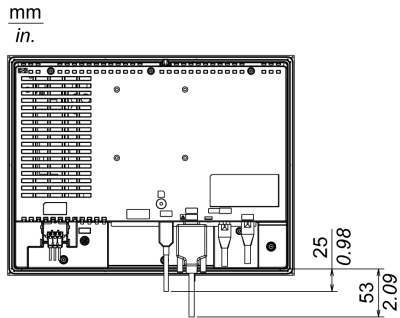

NOTE: All the above values are designed with cable bending in mind. The dimensions given here are representative values depending on the type of connection cable in use. Therefore, these values are intended for reference only.

Dimensions with Cables: HMIGTO6315

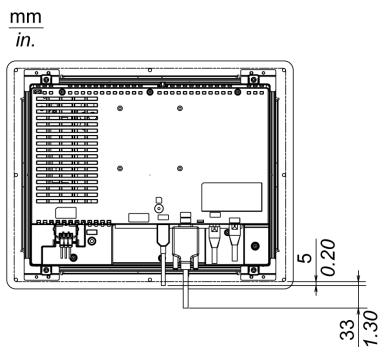

NOTE: All the above values are designed with cable bending in mind. The dimensions given here are representative values depending on the type of connection cable in use. Therefore, these values are intended for reference only.

Panel Cut Dimensions

Create a panel cut and insert the panel into the opening from the front.

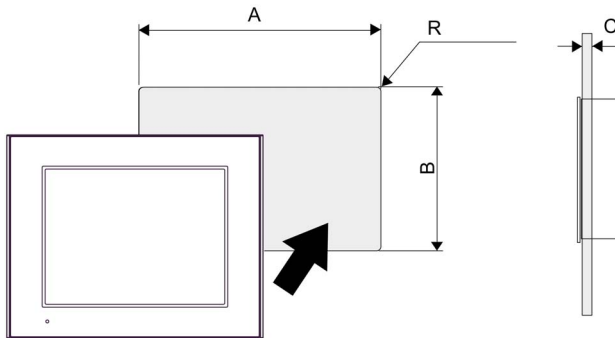

	A	B	C	R
HMIGTO6310	301.5 mm (+1, -0 mm) (11.87 in (+0.04, -0 in))	227.5 mm (+1, -0 mm) (8.96 in (+0.04, -0 in))	1.6...5 mm (0.06...0.2 in)	3 mm (0.12 in) maximum
HMIGTO6315	340.5 mm (+1, -0 mm) (13.41 in (+0.04, -0 in))	266.5 mm (+1, -0 mm) (10.49 in (+0.04, -0 in))		

NOTE: Before designing the panel cut, refer to Installation.

Installation Fastener Dimensions

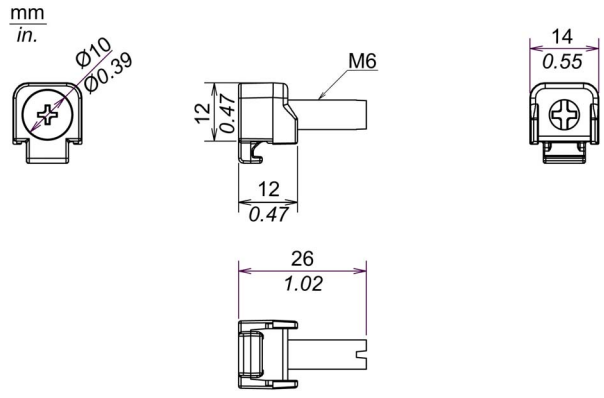

Chapter 5

Installation and Wiring

What Is in This Chapter?

This chapter contains the following sections:

Section	Topic	Page
5.1	Installation	108
5.2	Wiring Principles	113
5.3	SD Card Insertion/Removal	119
5.4	USB Cable Clamp	124

Section 5.1

Installation

Installation Procedures

Introduction

The installation fasteners are required when installing the panel.

Mount the panel in an enclosure that provides a clean, dry, robust, and controlled environment:

- HMIGTO (except HMIGTO2315 / HMIGTO5315 / HMIGTO6315): IP65, Type 1, Type 4X [Indoor Use Only] or Type 13 enclosure.
- HMIGTO2315 / HMIGTO5315 / HMIGTO6315: IP66k, Type 1, Type 4X [Indoor Use Only] or Type 13 enclosure.

Installation Requirements

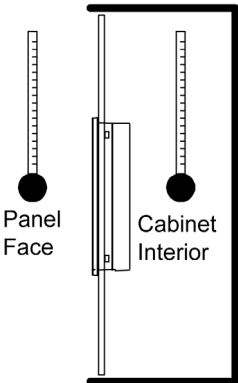
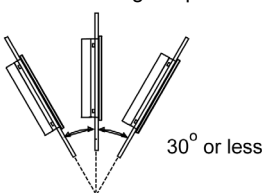
<p>Check that the installation wall or cabinet's surface is flat, in good condition and has no jagged edges. Metal reinforcing strips may be attached to the inside of the wall, near the panel-cut, to increase its rigidity.</p>
<p>Decide on the thickness of the enclosure wall, based on the level of strength required: 1.6...5 mm (0.06...0.2 in).</p>
<p>Be sure that the surrounding air temperature and the ambient humidity are within their designated ranges. Surrounding air temperature: 0...50 °C (32...122 °F) or 0...55 °C (32...131 °F) (see the Environment Specifications for your HMIGTO); ambient humidity: 10 to 90%RH; wet bulb temperature: maximum 39 °C [102 °F]. When installing the panel in a cabinet or enclosure, the surrounding air temperature is the cabinet's or enclosure's internal temperature.</p>

<p>Be sure that heat from surrounding equipment does not cause the panel to exceed its standard operating temperature.</p>
<p>When installing the panel in a slanted position, the panel face should not incline more than 30°.</p>

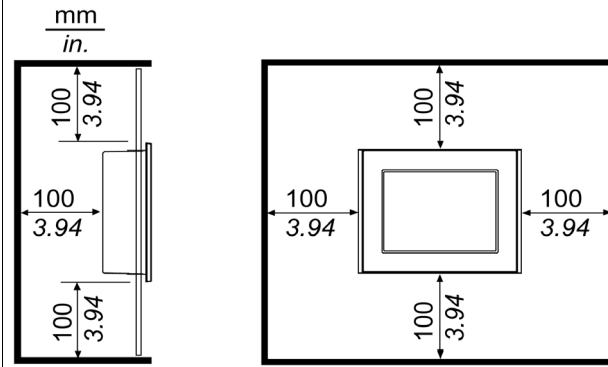
<p>When installing the panel in a slanted position with an incline more than 30°, the ambient temperature must not exceed 40 °C (104 °F). You may need to use forced air cooling (fan, A/C) to ensure that the ambient operating temperature is 40 °C or less (104 °F or less).</p>

For easier maintenance, operation and improved ventilation, install the panel at least 100 mm (3.94 in) away from adjacent structures and other equipment as shown in the following illustration:



The holes on the rear of the panel (except HMIGTO1300/1310) do not correspond to VESA 75 mm standards. Do not attach the panel to a commercial-type VESA arm.

Panel Mounting Procedure: (Except HMIGTO2315 / HMIGTO5315 / HMIGTO6315)

NOTICE

PANEL UNSTEADY WHEN UNSECURED

Keep HMIGTO stabilized in the panel-cut while you are installing or removing the screw fasteners.

Failure to follow these instructions can result in equipment damage.

Step	Action
1	Place the panel on a clean and level surface with the display facing downward.
2	Check that the panel's gasket is seated securely into the gasket's groove, which runs around the perimeter of the panel frame.
3	Cut a hole in the installation panel as defined by the HMIGTO's panel cutout dimensions. HMIGTO1300 / HMIGTO1310 (see page 46) HMIGTO2300 / HMIGTO2310 (see page 61) HMIGTO3510 / HMIGTO4310 (see page 74) HMIGTO5310 (see page 89) HMIGTO6310 (see page 104)
4	Insert the HMIGTO into the panel-cut.

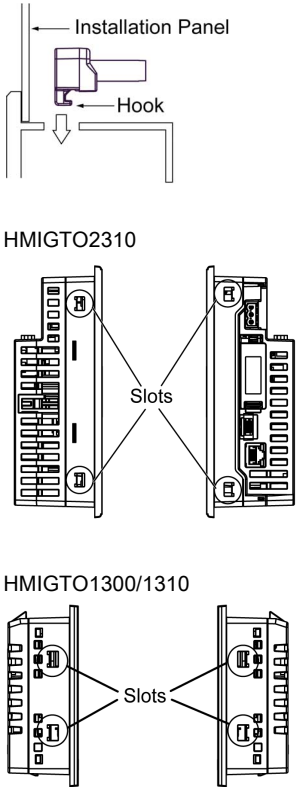
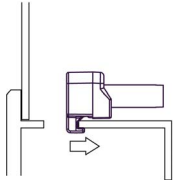
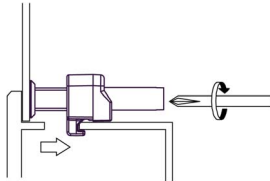
Step	Action
5	<p>Insert the installation fasteners into the HMIGTO's insertion slots on the top and bottom sides (left and right sides for the HMIGTO1300/1310). Slide the fasteners to the back. If the fasteners are not correctly attached, the HMIGTO may shift or fall out.</p>  <p>HMIGTO2310</p> <p>HMIGTO1300/1310</p>
6	<p>Insert each of the fasteners shown below. Make sure that you pull the fastener back until it is flush with the rear of the attachment hole insert.</p> 
7	<p>Use a Phillips screwdriver to tighten each fastener screw and secure the panel in place. The necessary torque is 0.5 Nm (4.4 lb•in).</p> 

NOTICE

BROKEN ENCLOSURE

- Do not exert more than 0.5 Nm (4.4 lb•in) of torque when tightening the fastener's screws.
- Use on flat surface of a Type 1, Type 4X (Indoor Use Only) or Type 13 Enclosure.

Failure to follow these instructions can result in equipment damage.

Removal Procedure: (Except HMIGTO2315 / HMIGTO5315 / HMIGTO6315)

Step	Action
1	Loosen the installation fasteners (4) from the HMIGTO.
2	Remove the HMIGTO slowly from the panel while pressing the projections on the top of the HMIGTO.

1 Projections

NOTE:

- You could damage the HMIGTO if you try to remove it without holding down the projections.
- Watch your fingers so they do not get caught when holding down the projections.

⚠ CAUTION

RISK OF INJURY
Do not drop the HMIGTO when you remove it from the panel.

- Hold the HMIGTO in place after removing the fasteners.
- Use both hands.

Failure to follow these instructions can result in injury or equipment damage.

HMIGTO2315 / HMIGTO5315 / HMIGTO6315 Panel Mounting Procedure

⚠ CAUTION

RISK OF INJURY
Do not drop the HMIGTO when you install or remove it from the panel.

- Hold the HMIGTO in place after removing the M4 Hex nuts and brackets.
- Use both hands.

Failure to follow these instructions can result in injury or equipment damage.

NOTICE

PANEL UNSTEADY WHEN UNSECURED
Keep panel stabilized in the panel-cut while you are installing or removing the M4 Hex nuts and brackets.

Failure to follow these instructions can result in equipment damage.

Step	Action
1	Place the panel on a clean and level surface with the display facing downward.
2	Confirm that the panel's gasket is seated properly on the rear of the panel.

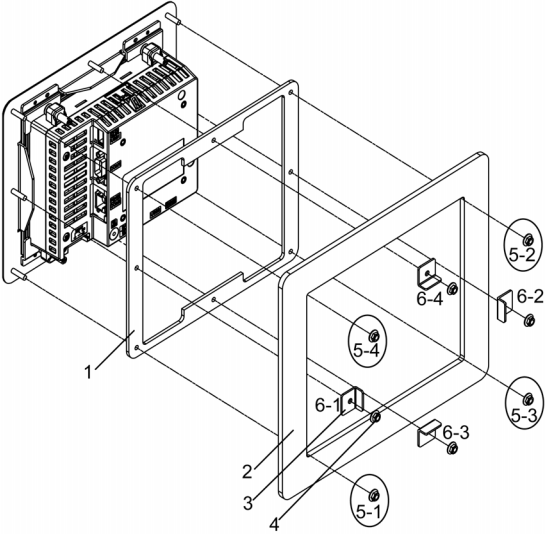
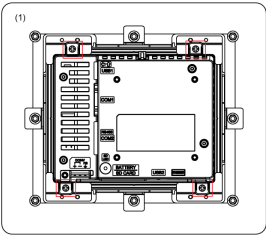
Step	Action
3	Make a hole in the panel as defined by the HMIGTO panel cutout dimensions. HMIGTO2315 (see page 61) HMIGTO5315 (see page 89) HMIGTO6315 (see page 104)
4	Insert the HMIGTO into the panel-cut.  <p>1 Gasket 2 Panel 3 Brackets 4 M4 Hex Nut 5 Read Step 5. 6 Read Step 6.</p>
5	Tighten the four corners of the rear of the panel with the M4 Hex nuts, in the order shown in the example in Step 4. Use an M4 box-type screwdriver to tighten each M4 Hex nut and secure the panel in place. The necessary torque is 0.5 Nm (4.4 lb•in). If the M4 Hex nuts are not correctly attached, the panel may shift or fall out.
6	Attach the bracket onto the screws in the middle between the M4 Hex nuts in the order shown in the example in Step 4. Use an M4 box-type screwdriver to tighten each M4 Hex nut and secure the panel in place. The necessary torque is 0.5 Nm (4.4 lb•in). If the M4 Hex nuts are not correctly attached, the panel may shift or fall out.
7	Tighten all the M4 Hex nuts again. The necessary torque is 0.5 Nm (4.4 lb•in). NOTE: Do not loosen the installation fasteners, marked with red squares below.  <p>1 Panel</p>

NOTICE

BROKEN ENCLOSURE

- Do not exert more than 0.5 Nm (4.4 lb•in) of torque when tightening the M4 Hex nuts.
- Use on flat surface of a Type 1, Type 4X (Indoor Use Only) or Type 13 Enclosure.

Failure to follow these instructions can result in equipment damage.

Section 5.2

Wiring Principles

Overview

This section presents the HMIGTO wiring principles.

What Is in This Section?

This section contains the following topics:

Topic	Page
Connecting the Power Cord	114
Connecting the Power Supply	116
Grounding	118

Connecting the Power Cord

⚠ WARNING

EXCESSIVE ELECTROMAGNETIC INTERFERENCE

- When the functional ground (FG) terminal is connected, be sure the wire is grounded. Not grounding the HMIGTO can result in excessive Electromagnetic Interference (EMI). Grounding is required to meet EMC level immunity.
- Remove power before wiring the HMIGTO's power terminals.
- The DC model uses only 24 Vdc power. Using any other level of power can damage both the power supply and the HMIGTO.
- Since the HMIGTO is not equipped with a power switch, be sure to connect a power switch to the power supply.
- Be sure to ground the HMIGTO's FG terminal.
- Replace and secure all elements of the system before applying power to the HMIGTO.

Failure to follow these instructions can result in death, serious injury, or equipment damage.

NOTE: The shield ground (SG) and FG terminals are connected internally in the panel.

DC Power Cord Preparation

- Make sure that the ground wire is either the same or heavier gauge than the power wires.
- Do not use aluminum wires in the power supply's power cord.
- If the ends of the individual wires are not twisted correctly, the wires may create a short circuit.
- Wherever possible, use wires that are 0.75 to 2.5 mm² (AWG 18 - 13) for the power cord, and twist the wire ends before attaching the terminals.
- The conductor type is solid or stranded wire.
- Field wiring terminal marking for wire type (75 °C [167 °F] copper conductors only).

DC Power Supply Connector (Plug) Specifications: Spring Clamp Terminal Blocks

HMIGTO1300/1310 / HMIGTO2300/2310/2315 / HMIGTO3510/4310

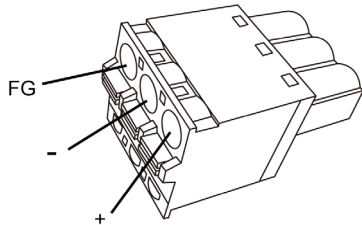

HMIGTO5310/5315 / HMIGTO6310/6315

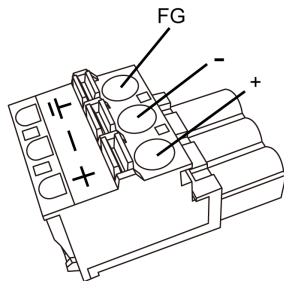

Connection	Wire
+	24 Vdc
-	0 Vdc
FG	Grounded terminal connected to the panel chassis.

How to Connect the DC Power Cord

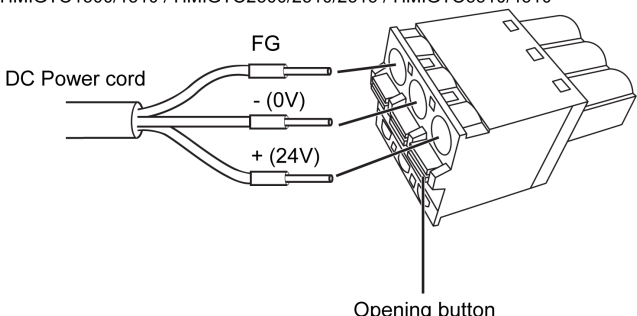
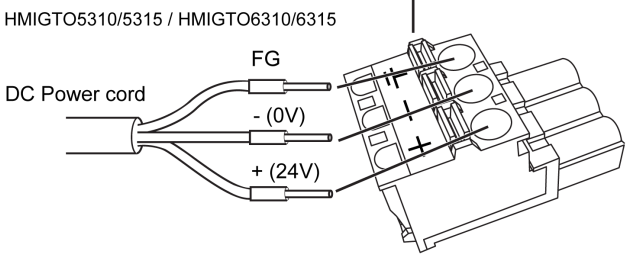
Step	Action
1	Confirm that the power cord is not connected to the power supply.
2	Check the rated voltage and remove the "DC24V" sticker on the DC power supply connector.
3	Remove 10 mm (0.39 in) of the vinyl membrane off the ends of the power cord wires.
4	If using stranded wire, twist the ends. Tinning the ends with solder reduces risk of fraying and ensures good electrical transfer.
5	Push the Opening button with a small and flat screwdriver to open the desired pin hole.
6	<p>Insert each pin terminal into its corresponding hole. Release the Opening button to clamp the pin in place.</p> <p>HMIGTO1300/1310 / HMIGTO2300/2310/2315 / HMIGTO3510/4310</p>  <p>HMIGTO5310/5315 / HMIGTO6310/6315</p> 
7	After inserting all three pins, insert the power plug into the power connector on the panel.

NOTE:

- Do not solder the wire directly to the power receptacle pin.
- To prevent the possibility of a terminal short, use a pin terminal that has an insulating sleeve.
- You can use the DC power connector for HMIGTO1300/1310 / HMIGTO2300/2310/2315 / HMIGTO3510/4310 to supply power to HMIGTO5310/5315 / HMIGTO6310/6315. However the reverse is not possible. You cannot use the power connector for HMIGTO5310/5315 / HMIGTO6310/6315 on HMIGTO1300/1310 / HMIGTO2300/2310/2315 / HMIGTO3510/4310.

Connecting the Power Supply

Precautions

- You must use a 24 Vdc input unit with a Class 2 power supply.
- To increase the electromagnetic noise resistance, make sure that you twist the ends of the power cord wires before connecting them to the power plug.
- The panel's power supply cord should not be bundled with or kept close to main circuit lines (high voltage, high current), or input/output signal lines.
- Connect a lightning surge absorber to handle power surges.
- To reduce electromagnetic noise, make the power cord as short as possible.

⚠ WARNING

SHORT CIRCUIT, FIRE, OR UNINTENDED EQUIPMENT OPERATION

Avoid excessive force on the power cable to prevent accidental disconnection

- Securely attach power cables to the HMIGTO or cabinet.
- Use the designated torque to tighten the unit terminal block screws.
- Install and fasten the HMIGTO on installation panel or cabinet prior to connecting power supply and communication lines.

Failure to follow these instructions can result in death, serious injury, or equipment damage.

Power Supply Connections

When supplying power to the panel, separate the input/output and power lines, as shown.

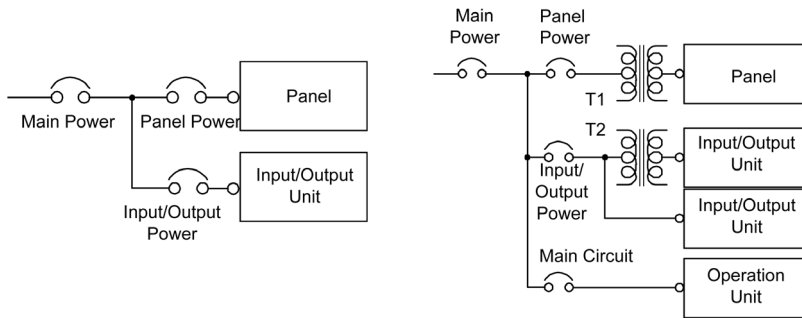

NOTE:

The following shows a lightning surge absorber connection:

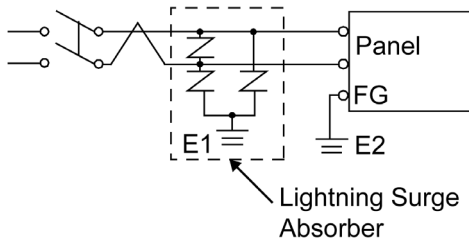

- Ground the surge absorber (E1) separately from the panel (E2).
- Select a surge absorber that has a maximum circuit voltage greater than that of the peak voltage of the power supply.

If the supplied voltage exceeds the panel range, connect a constant voltage transformer.

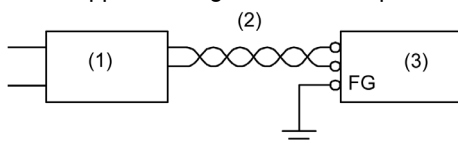

- 1 Constant voltage transformer
- 2 Twisted-pair cord
- 3 panel

Select a power supply low in noise for between the line and ground. If there is an excess amount of noise, connect an insulating transformer.

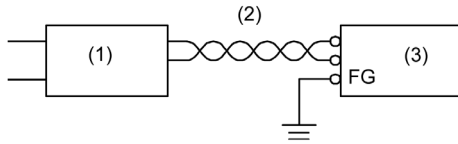

- 1 Insulating transformer
- 2 Twisted-pair cord
- 3 panel

NOTE: Use constant voltage and insulating transformers with capacities exceeding the Power Consumption value.

Grounding

Exclusive Grounding

When supplying power to the panel, separate the input/output and power lines as shown below. Connect the frame ground (FG) terminal on the power plug to an exclusive ground.

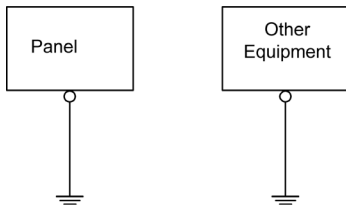

Precautions

Electromagnetic Interference (EMI) can be created if the devices are improperly grounded. EMI can cause loss of communication. Do not use common grounding, except for the authorized configuration described below. If exclusive grounding is not possible, use a common grounding point.

Correct grounding

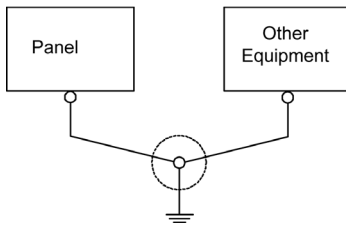

Incorrect grounding

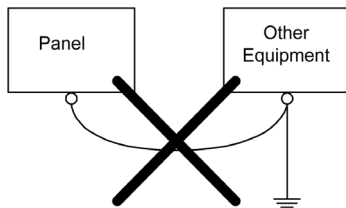

- Check that the grounding resistance is 100 Ω or less.*¹
- The FG wire should have a cross sectional area greater than 2 mm² (AWG 14) ⁽¹⁾. Create the connection point as close to the panel as possible, and make the wire as short as possible. When using a long grounding wire, replace the thin wire with a thicker wire, and place it in a duct.
- FG and SG terminals are internally connected in the panel. When connecting an external device to the panel using the SG terminal, check that you do not create a short-circuit loop when you set up the system.

*¹ Observe local codes and standards. Ensure that the ground connection has a resistance of 100 Ω and that the ground wire has a cross-section of at least 2 mm² or AWG 14.

Section 5.3

SD Card Insertion/Removal

What Is in This Section?

This section contains the following topics:

Topic	Page
Introduction	120
Inserting the SD Card	121
Removing the SD Card	122
SD Card Data Backup	123

Introduction

CAUTION

LOSS OF DATA

When using the HMIGTO and a SD card, observe the following to avoid losing valuable data:

- Since accidental data loss can occur at any time, back up HMIGTO screen and SD card data regularly. Once HMIGTO data is lost, it cannot be recovered.
- Before removing the SD card from the HMIGTO, stop all operation on it using the SD card removal process. If you do not run the removal process and forcibly extract the SD card, data on the SD card may become corrupted.
- While a SD card is accessed, do not turn OFF or reset the HMIGTO, and do not insert or remove the SD card. Doing so could damage the SD card, or corrupt its data.
- Before using the SD card, familiarize yourself with the SD card's front and rear face orientation, as well as the position of the SD card connectors. If the SD card is not positioned correctly when inserted into the HMIGTO, the card's internal data and HMIGTO could become damaged.

Failure to follow these instructions can result in injury or equipment damage.

NOTICE

LOSS OF DATA

When handling the SD card, follow the instructions below to prevent internal data on the SD card from being destroyed or a SD card malfunction from occurring:

- Avoid storing the SD card where there is static electricity or electromagnetic waves.
- Avoid storing the SD card in direct sunlight, near a heater, or other locations where high temperatures can occur.
- Do not bend the SD card.
- Do not drop or strike the SD card against another object.
- Keep the SD card dry.
- Do not touch the SD card connectors.
- Do not disassemble or modify the SD card.
- Use only SD cards formatted using FAT or FAT32. The HMIGTO does not recognize NTFS formatted SD cards. Format the SD card on your computer using FAT or FAT32.

Failure to follow these instructions can result in equipment damage.

Inserting the SD Card

NOTE: As shown in the image below (example on the left-hand side), you can set the Write-Control Tab to prevent write operations to the SD card. Push the tab up, as shown in the example on the right-hand side to release the lock and enable writing to the SD card. Before using a commercial-type SD card, read the manufacturer's instructions.

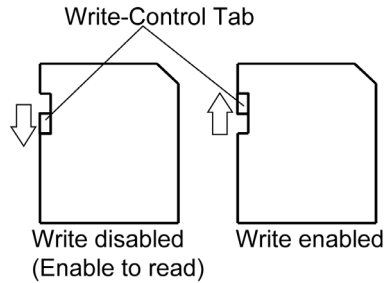

Step	Action
1	<p>Pull on the tab and open the SD card cover.</p> <p>(1) Tab</p>
2	<p>Insert the SD card into the SD card interface, and push until you hear it "click".</p>
3	<p>Close the SD card cover.</p>

Removing the SD Card

Introduction

 <b style="font-size: 1.2em;">CAUTION
<p>LOSS OF DATA</p> <p>When using the HMIGTO and a SD card, observe the following to avoid losing valuable data:</p> <ul style="list-style-type: none"> ● Since accidental data loss can occur at any time, back up HMIGTO screen and SD card data regularly. Once HMIGTO data is lost, it cannot be recovered. ● Before removing the SD card from the HMIGTO, stop all operation on it using the SD card removal process. If you do not run the removal process and forcibly extract the SD card, data on the SD card may become corrupted. ● While a SD card is accessed, do not turn OFF or reset the HMIGTO, and do not insert or remove the SD card. Doing so could damage the SD card, or corrupt its data. ● Before using the SD card, familiarize yourself with the SD card's front and rear face orientation, as well as the position of the SD card connectors. If the SD card is not positioned correctly when inserted into the HMIGTO, the card's internal data and HMIGTO could become damaged. <p>Failure to follow these instructions can result in injury or equipment damage.</p>

Removing the SD Card

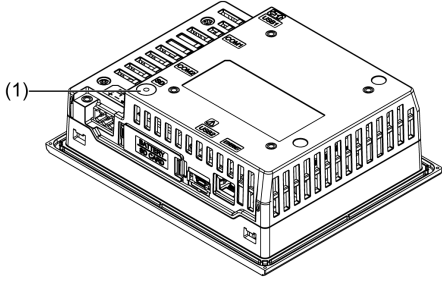
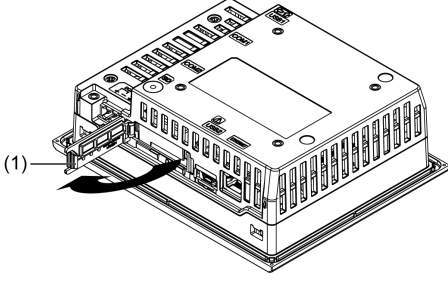
Step	Action
1	<p>Make sure that the SD card access LED is off.</p> <div style="text-align: center; margin: 10px 0;">  </div> <p style="margin-left: 20px;">1 SD card Access LED</p>
2	<p>Push down the tab on the SD card cover; then pull open the cover.</p> <div style="text-align: center; margin: 10px 0;">  </div> <p style="margin-left: 20px;">1 Tab</p>
3	<p>Push the SD card once to release, and pull out the card. After removing the card, close the cover.</p> <p>NOTE: After using the SD card, store the SD card in its case or other safe location.</p>

SD Card Data Backup

To make your backups, you can either insert the SD Card directly into the SD Card interface on your computer, or use a commercially available SD Card reader.

Section 5.4

USB Cable Clamp

Overview

This section presents the USB cable clamp.

What Is in This Section?

This section contains the following topics:

Topic	Page
USB Cable Clamp for USB (Type A)	125
USB Holder for USB (mini-B)	127

USB Cable Clamp for USB (Type A)

Introduction

When using a USB device, attaching a USB cable clamp to the USB interface to prevent the USB cable from being disconnected.

⚠ DANGER

POTENTIAL FOR EXPLOSION

- Verify the power, input, and output (I/O) wiring are in accordance with Class I, Division 2 wiring methods.
- Substitution of any components may impair suitability for Class I, Division 2.
- Confirm that the USB cable has been fixed with the USB cable clamp before using the USB interface.
- Remove power before attaching or detaching any connectors to or from the unit.

Failure to follow these instructions will result in death or serious injury.

Attaching the USB Cable Clamp

NOTE: Watch your fingers. The edge of the clip is sharp.

Step	Action
1	<p>Mount the clip to the USB mark  connector shell so that it overlaps. The clip matches the 27...43.5 mm (1.06...1.71 in) length of the USB connector.</p>
2	<p>Align the clip and the USB cable connector shell. Adjust the position of the holes where the clip is attached. To ensure stability, select the clip-hole position that is closest to the base of the connector shell.</p>

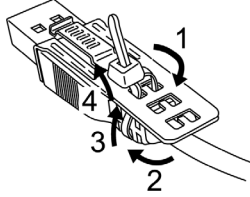
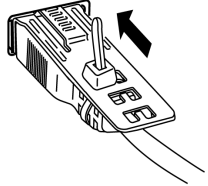
Step	Action
3	<p>As shown, pass the tie through the clip hole. Next, turn the tie and pass it through the head so that the USB cable can pass through the center of the tie loop. The clip is now attached to the USB cable.</p>  <p>NOTE:</p> <ul style="list-style-type: none">• Check the direction of the head beforehand. Make sure that the USB cable is through the center of the tie loop and that the tie can pass through the head.• You can substitute the tie provided with commercially available ties with a width of 4.8 mm (0.19 in) and thickness of 1.3 mm (0.05 in).
4	<p>While pressing the grip on the clip, insert the cable from step 3 all the way into the USB host interface. Make sure that the clip tab is secured to the USB cable attached to the HMIGTO.</p> 

Removing the USB Cable

Remove the USB cable while pushing the grip section of the clip.

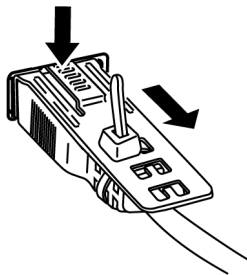

USB Holder for USB (mini-B)

Introduction

When using a USB device, you can attach a USB holder to the USB (mini-B) interface to prevent the USB cable from being disconnected.

⚠ DANGER

POTENTIAL FOR EXPLOSION

- Verify the power, input, and output (I/O) wiring are in accordance with Class I, Division 2 wiring methods.
- Substitution of any components may impair suitability for Class I, Division 2.
- Confirm that the USB cable has been fixed with the USB cable clamp before using the USB interface.
- Remove power before attaching or detaching any connectors to or from the unit.

Failure to follow these instructions will result in death or serious injury.

Attaching the USB Holder

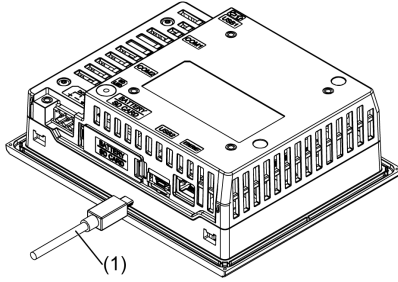
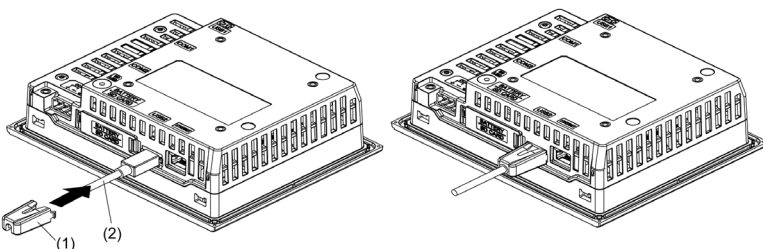
Step	Action
1	<p>Insert the USB cable into the USB (mini-B) interface.</p>  <p style="text-align: center;">1 USB cable</p>
2	<p>Attach the USB holder to fix the USB cable in place. Insert the USB holder into the USB (mini-B) interface.</p>  <p style="text-align: center;">1 USB holder 2 USB cable</p>

Removing the USB Holder

Remove the USB holder by pressing the tabs from the sides.

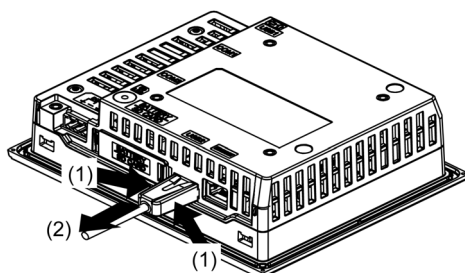

Chapter 6

Maintenance

Overview

This chapter explains how to maintain your panel.

What Is in This Chapter?

This chapter contains the following topics:

Topic	Page
Regular Cleaning	130
Replacing the Installation Gasket	131
Periodic Check Points	133
Replacing the Primary Battery	134

Regular Cleaning

Cleaning the display

<i>NOTICE</i>
EQUIPMENT DAMAGE <ul style="list-style-type: none">● Power off the panel before cleaning it.● Do not use hard or pointed objects to operate the touch panel as you may damage the panel surface.● Do not use paint thinner, organic solvents, or a strong acid compound to clean the unit. Failure to follow these instructions can result in equipment damage.

When the surface or the frame of the display gets dirty, soak a soft cloth in water with a neutral detergent, wring the cloth tightly and wipe the display.

Replacing the Installation Gasket

Overview

The installation gasket provides protection against dust and moisture.

NOTICE

GASKET AGING

- Inspect the gasket periodically as required by your operating environment to keep the initial IP level.
- Change the gasket at least once a year, or as soon as scratches or dirt become visible.

Failure to follow these instructions can result in equipment damage.

Installing the Installation Gasket

NOTE: For instructions on how to install the installation gasket when using HMIGTO2315 / HMIGTO5315 / HMIGTO6315, see HMIGTO2315 / HMIGTO5315 / HMIGTO6315 Panel Mounting Procedure ([see page 109](#)).

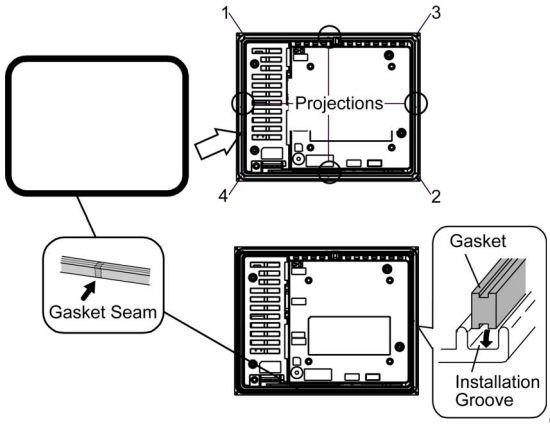
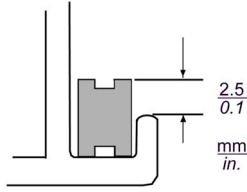
Stage	Description
1	Place the panel on a flat, level surface, with the display face pointing down.
2	Remove the gasket from the panel.
3	<p>Attach the new gasket to the panel. Position the gasket in the installation groove so that the gasket seam is at the bottom of the panel. First, insert the gasket into the four corners, in the order shown in the image below. Then, insert the rest of the gasket into the installation groove.</p> <p>NOTE:</p> <ul style="list-style-type: none"> • The center of the panel bezel's installation groove is ribbed. Make sure that you insert the gasket all the way in without catching the ribbed sections. • When using a tool to insert the gasket, make sure that the tool does not catch the rubber gasket and cause a tear. 
4	<p>The upper surface of the gasket should protrude approximately 2.0 mm (0.06 in.) from the groove. Check the gasket is inserted correctly before installing the HMIGTO into a panel.</p> 

The gasket must be inserted correctly into the groove for IP65f moisture resistance for the panel. IP66k moisture resistance for HMIGTO2315/HMIGTO5315/HMIGTO6315).

 **CAUTION**

EQUIPMENT DAMAGE

- Since the gasket is flexible but not elastic, be careful not to stretch it unnecessarily.
- Make sure the gasket seam is not inserted into any of the panel corners.
- Insert the gasket in the installation groove

Failure to follow these instructions can result in injury or equipment damage.

Periodic Check Points

Operation Environment

- Is the operating temperature within the allowable range? Refer to Environmental Specifications:
 - HMIGTO1300/1310 (*see page 36*)
 - HMIGTO2300/2310/2315 (*see page 49*)
 - HMIGTO3510/4310 (*see page 64*)
 - HMIGTO5310/5315 (*see page 78*)
 - HMIGTO6310/6315 (*see page 93*)
- Is the operating humidity within the specified range? (10%RH to 90%RH, dry bulb temperature of 39 °C (102.2 °F) or less)
- Is the operating atmosphere free of corrosive gases?

When the HMIGTO is inside a panel, the ambient environment refers to the interior of the panel.

Electrical Specifications

Is the input voltage appropriate?

19.2...28.8 Vdc

Related Items

- Are all power cords and cables connected properly? Are there any loose cables?
- Are all mounting brackets holding the unit securely?
- Are there scratches or traces of dirt on the installation gasket?

Replacing the Primary Battery

Introduction

The replacement battery HMIZGBAT (sold separately) for the primary battery in the HMIGTO is available from Schneider Electric.

NOTE: The HMIGTO1300/1310 and HMIGTO2300 are not equipped with a primary battery.

⚡ ⚠ DANGER

HAZARD OF ELECTRIC SHOCK, EXPLOSION, OR ARC FLASH

- Follow the procedures step by step to replace the battery correctly and safely.
- Before replacing the battery, turn OFF the HMIGTO's power.

Failure to follow these instructions will result in death or serious injury.

⚠ DANGER

EXPLOSION, FIRE, OR CHEMICAL HAZARD

- Use only the replacement battery HMIZGBAT manufactured by Schneider Electric.
- Do not cause a short circuit.
- Recycle or properly dispose of used batteries.

Failure to follow these instructions will result in death or serious injury.

NOTICE

LOSS OF DATA

The primary battery is non-rechargeable, and is used for data backup of memory and the internal clock. If the primary battery is depleted, the backup data is lost. One month before the primary battery is completely depleted, a message will appear to indicate it is time to replace the primary battery.

- Replace the battery within one month after the message appears. Otherwise, backup data may be lost.
- Complete replacing the battery within ten minutes of shutting down the HMIGTO.
- The primary battery replacement time (within a month after the message appears) is only a guideline. When backup SRAM data and clock data is lost after the message appears, Schneider Electric does not perform data recovery/retrieval. Schneider Electric does not accept any responsibility for the loss of data.
- Replace the primary battery regularly every five years after you purchase the HMIGTO.

Failure to follow these instructions can result in equipment damage.

Step	Action
1	Disconnect the power supply from the HMIGTO.
2	Touch the housing or ground connection (not the power supply) to discharge any electrostatic charge from your body.
3	Open the SD card Interface Cover by pressing its tab. Next, open the Replacement battery Insertion Cover by pressing its tab.

(1) SD card Interface Cover / Tab
 (2) Replacement battery Insertion Cover / Tab

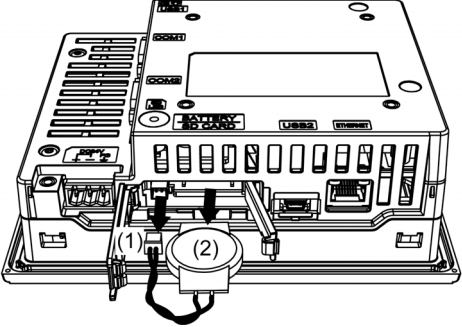
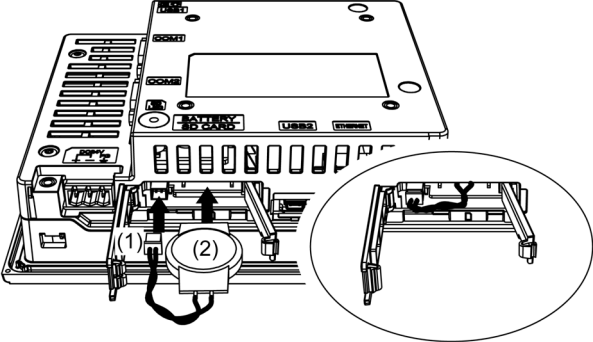
Step	Action
4	<p data-bbox="491 208 906 230">Remove the primary battery and connector.</p>  <p data-bbox="491 568 676 622">1 Connector 2 Primary battery</p>
5	<p data-bbox="491 633 932 656">Attach the new primary battery and connector.</p> 
6	<p data-bbox="491 1059 1262 1081">First close the replacement battery cover; then close the SD card interface cover.</p> <p data-bbox="491 1093 1385 1151">NOTE: Make sure that the cables are inserted completely inside the enclosure. Otherwise, you can damage the cables when you close the cover.</p>
7	<p data-bbox="491 1162 922 1184">Reconnect the power supply to the HMIGTO.</p>



A

Accessories, 19

B

battery, 134

C

caution

- loss of data, 120, 120, 122
- equipment damage, 132
- injury, 111, 111
- loss of communication, 42, 42, 43, 56, 57, 70, 71, 85, 86, 100, 101

CE marking, 12

Certifications and Standards, 12

cleaning, 130

clock, 39, 53, 67, 82, 97

connecting the power cord, 114

connecting the power supply, 116

D

danger

- arc flash, 134
- chemical hazard, 134
- electric shock, 41, 43, 55, 57, 69, 71, 84, 86, 99, 101, 134
- explosion, 125, 127, 134, 134
- fire, 134

dimensions, 44, 58, 72, 87, 102

F

function keys, 39, 67

G

gasket, 132

grounding, 118

I

installation

- procedures, 108

installation gasket, 131

K

KC marking, 13

M

maintenance, 129

- check points, 133

Maintenance

- Cleaning, 130

maintenance accessories, 20

memory, 39, 53, 67, 82, 97

N

notice

- panel unsteady when unsecured, 109
- loss of data, 134
- overtorque, 110, 112
- panel unsteady when unsecured, 111

O

optional accessories, 20

P

parts identification and functions, 23

power plug, 114

R

replacing the battery, 134

S

SD Card, 119

- backup, 123
- insertion, 121

SD Card accessories, 19

serial interface accessories, 19

specifications

- COM, 41, 55, 57, 71, 84, 86, 99, 101
- COM1, 40, 54, 55, 68, 69, 83, 84, 98, 99
- COM2, 40, 43, 54, 57, 68, 71, 83, 86, 98, 101
- display, 38, 52, 66, 81, 96
- electrical, 35, 48, 63, 77, 92
- environmental, 36, 49, 64, 78, 93
- Ethernet, 98
- interfaces, 40, 54, 68, 83, 98
- SD Card, 54, 68, 98
- structural, 37, 50, 65, 79, 94
- USB, 40, 40, 54, 54, 68, 68, 83, 83, 83, 98

T

touch panel, 39, 53, 67, 82, 97

U

USB

- cable clamp for USB Type A, 125
- holder mini-B, 127

USB interface accessories, 19

W

warning

- electromagnetic interference, *114*
- fire, *116*
- short circuit, *116*
- unintended equipment operation, *7, 116*